

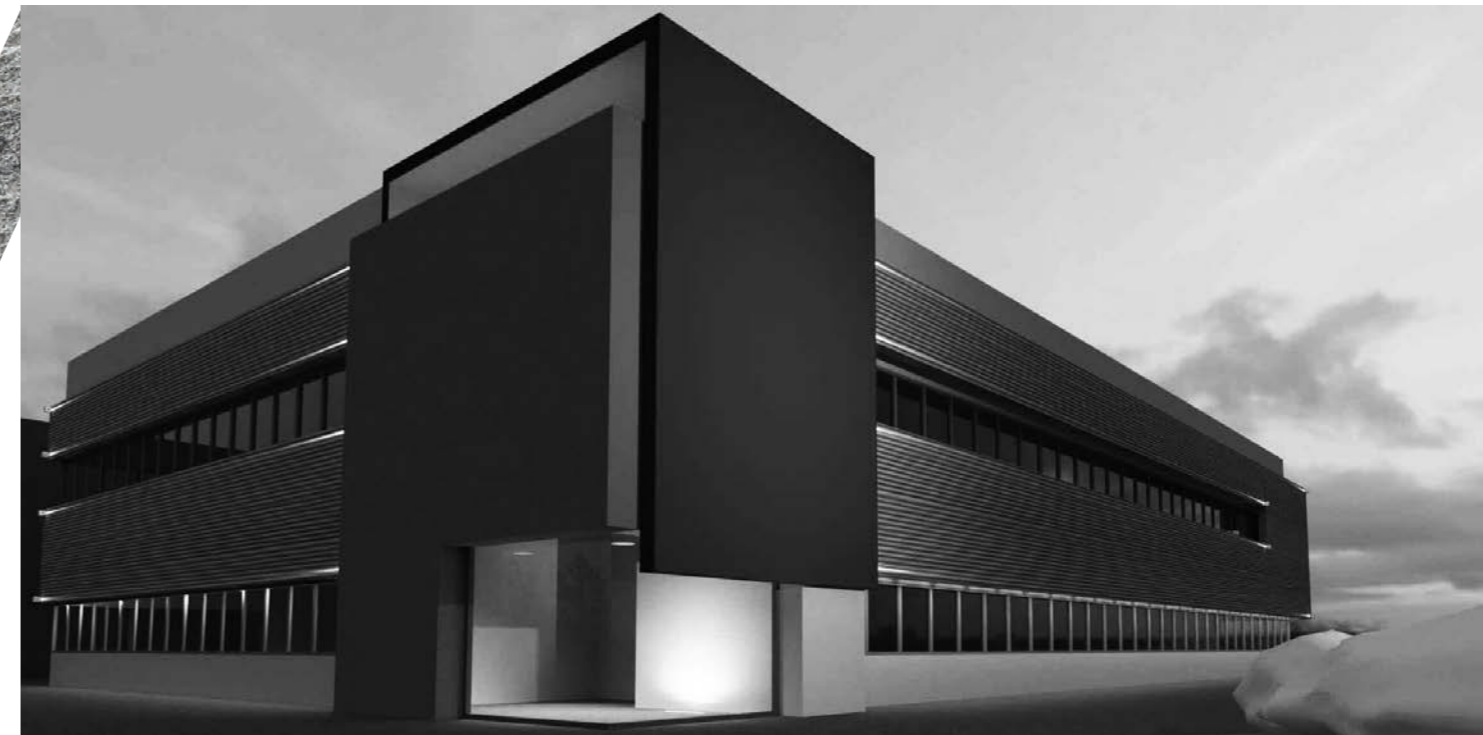

MODERNO



*Una storia
consolidata
nel tempo*



In ROBERTO MARELLA S.p.A. la maniglia rappresenta un "luogo particolare". E' un oggetto privilegiato che non si limita ad essere risposta funzionale, ma esprime, nella materia e nella forma, il piacere estetico di un semplice gesto.

ROBERTO MARELLA S.p.A. mantiene e sviluppa una Leadership sul mercato nazionale e internazionale, diventando l'unica azienda italiana con una produzione **100% Made in Italy**, completa e specializzata nella produzione di maniglie e accessori per cucina, bagno e mobile, con un'ampia gamma prodotto sempre più completa in stile e design.

In ROBERTO MARELLA S.p.A., the handle represents this "particular place". It's a privileged object, not only a functional response, it represents, in its features, the esthetical pleasure of a simple gesture.

*ROBERTO MARELLA S.p.A maintains and develops the Leadership on National and International market, becoming the only Italian company with a **completely 100% Made in Italy** production process, complete and specialized in the production of handles and accessories for kitchens, bathrooms and furniture, with a wide range of products even more complete in Style and Design.*



MARCO BORTOLIN

Terminati gli studi di arredamento e di interior design, matura esperienze nel campo del design industriale in qualità di designer ed art director nel mercato italiano, negli Stati Uniti ed attualmente anche nel mercato Russo. In collaborazione con Roberto Marella ha creato una nuova linea di maniglie moderne a marchio Marella Design, in cui emerge tutta la sua abilità artistica e l'eccellenza del Made in Italy, simbolo di qualità, ricerca, innovazione e originalità. *Upon graduation in interior design, he acquired experience in the field of industrial design as designer and art director in Italy, as well as in the United States and, currently, also in the Russian market. In collaboration with Bosetti Marella, he has created a new collection of modern handles, branded Marella Design, where he shows all his artistic skills and the excellence of Made in Italy, symbol of quality, research, innovation and originality.*



GHEORG SEEBACHER

“La curiosità è alla base della comprensione; è perciò essenziale vedere le persone come utilizzatori finali. Dobbiamo cercare di capire i loro valori, contesti culturali e le loro richieste, come future possibilità tecnologiche e collegare, infine, tutti questi aspetti. Attraverso questa comprensione, aspiro, con passione, a sviluppare concetti e implementarli, creando prodotti affascinanti in grado di soddisfare tanto le richieste emozionali quanto quelle funzionali.” *“Curiosity forms the basis of understanding. It is therefore essential to see people as users. We must seek to understand their values, cultural backgrounds, and demands as future technological possibilities and also connect all of these aspects. With this understanding, I passionately aspire to develop concepts and to implement them by creating fascinating products that meet emotional as well as functional requirements.”*



BALUTTO STUDIO

Un atelier in continuo fermento, laboratorio creativo ed officina di produzione. Fondato da Adriano Balutto, più volte nominato -“designer di best seller”-, si è arricchito da qualche anno di un nuovo apporto creativo, l'Arch. Veronica Balutto. L'attività dello studio Balutto è stata premiata svariate volte con prestigiosi riconoscimenti a livello internazionale. *Studio Balutto, an ever moving, creative lab and production workshop. Adriano Balutto is the founder and has been appointed as “Designer of Bestseller” several times; For some years, the new presence of the Architect Veronica Balutto, conveyed a new creative contribution. The Balutto atelier activity has been awarded several times with prestigious international identification.*



ALESSANDRO ELLI

Nasce in Brianza nel 1968, dopo il diploma, frequenta la SPD di Milano seguendo il Master in Disegno Industriale. Le aziende con cui collabora o ha collaborato sono: Axil, Bross, Di Liddo & Perego, Emme-mobili, I Carraro, Linfa, Nespoli - Consonni, Salcon imbottiti, Servetto, Pamar, YDF, Thre. La collezione Cubik progettata per Di Liddo & Perego vince il “premio speciale Tiziana Mascheroni” nell'ambito del concorso Yung & Design 2005. *Was born in Brianza in 1968, after the diploma, attended the SPD in Milan following the Master in Industrial Design. The companies with which it collaborates or has collaborated are: Axil, Bross, Di Liddo & Perego, Emme-mobili, I Carraro, Linfa, Nespoli - Consonni, Salcon imbottiti, Servetto, Pamar, YDF, thre. The Cubik collection designed for Di Liddo & Perego won the “Special Award Tiziana Mascheroni” within the Yung & Design 2005 contest.creativity.*



MICHELE FAINI

“In uno scenario sempre più competitivo nella ricerca, ma appiattito nel gusto, cerco di riportare i miei progetti alle radici della nostra cultura. Il mio obiettivo è soddisfare un bisogno, tenendo conto della ricerca del bello, dell'armonia e dell'estetica, unite alla funzionalità e all'utilità. Siamo geneticamente padroni di fascino ed eleganza, grazie a secoli di fastosa cultura artistica posta agli apici del mondo: la capacità di voltarsi indietro per andare avanti è, a mio parere, la marcia in più che porta a nuove strade di creatività pura.” *“In a period, increasingly competitive in the research, but flattened in the style, I try to bring my projects to the roots of our culture. My goal is to satisfy a need, taking into consideration the research of beauty, harmony and aesthetics, combined with the functionality and usefulness of products. Thanks to our artistic culture placed at the apex of the world, We are genetically owners of charm and elegance: The ability to look back, for going on, is, in my opinion, the extra edge leading to new avenues of pure creativity.”*

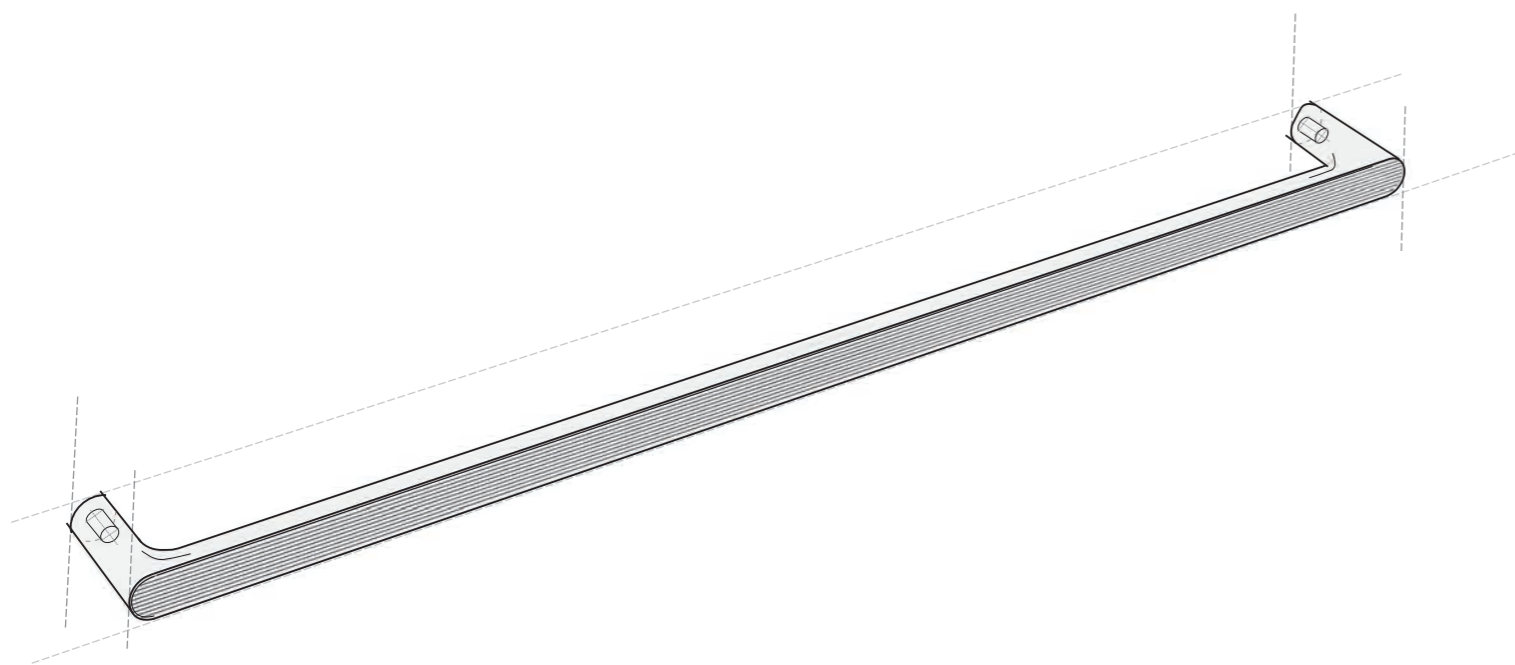

MARELLA DESIGNLAB

Marella Design Lab è il cuore pulsante, l'anima dell'azienda che, unito alla poliedrica fantasia dei designer con i quali collaboriamo, dà vita a nuovi prodotti di tendenza, oltre che funzionali.

Marella Design Lab è soprattutto «Ricerca e Sviluppo», non solo di nuove linee di prodotto, ma anche di ricercate finiture, materiali e innovative tecnologie di produzione.

La forza e l'originalità della nostra azienda nascono anche da strette collaborazioni con i nostri "Creativi" che, spinti dalla passione per la maniglia e da un talento innato per il disegno, creano, per noi, oggetti originali e unici nel loro genere.

TALENTO, FANTASIA, INNOVAZIONE che sfociano in idee vincenti e di tendenza, 100% Made in Italy.

Marella Design Lab is the beating heart, the soul of the Company which, combined with the creativity and imagination of our designers, gives life to new trendy and functional products.

Marella Design Lab is above all «Research and Development», not only of new products, but also of refined finishes, materials and innovative production technologies.

The strength and originality of our Company also born from the close collaboration with our "Creatives" who, driven by a passion for handles and innate talent for design, create original and unique objects for us.

TALENT, FANTASY, INNOVATION for trendy ideas, 100% Made in Italy.



AMADIO MICHIELETTI

Attenzione per i dettagli, conoscenza della storia e della tradizione, oltre una grande passione per la maniglia, in quanto oggetto, sono gli elementi che contraddistinguono i progetti dell'artista naturale. Arte, funzionalità, idee geniali che evolvono in raffinati ed unici oggetti di design e di arredo. Una passione diventata un vero bagaglio, una raccolta del passato rivisitata per un'arte contemporanea. Tutto questo e altro è il nostro amico Michieletti.

Attention to detail, knowledge of history and tradition, as well as a great passion for the handle, as an object, are all elements that distinguish the projects of the natural artist. Art, functionality, brilliant ideas that evolve into refined and unique design and furnishing objects. A passion that has become a real baggage, a collection of the past revisited for contemporary art. All this and more is our Friend Michieletti.



ENRICO VERONESE

“In un mondo dove tutto si trasforma e scorre velocemente, i dettagli sono ciò che fanno la differenza. Per questo, la ricerca di linee nuove e di particolari originali, che siano al contempo armonia e tendenza, rappresentano la sfida e un piacere immenso, che mi spingono ad abbozzare e fare continua ricerca in questo settore. Anche la maniglia segna e imprime il passaggio di un tempo”.

“In a world where everything changes and flows quickly, the details make the difference. For this reason, the research of new lines and original elements, which are also harmony and trend, represent the challenge and an immense pleasure. These elements push me to sketch and do continuous research in this sector. Even the handle marks and imprints the passage of the past”.

COLLEZIONI / INDEX COLLECTIONS

MANIGLIE ALU CONCEPT / ALU CONCEPT HANDLES:

Aqua	PAG. M.11
Aqua-Rama	PAG. M.17
Riva	PAG. M.25
Riva-Rama	PAG. M.31
Stilo	PAG. M.39
Trama+	PAG. M.45
Trama	PAG. M.49
Drop	PAG. M.55
Square	PAG. M.59
Line	PAG. M.61
Florida	PAG. M.63
Florida-O	PAG. M.67
Retta	PAG. M.71
Retta-O	PAG. M.75
Passante	PAG. M.79
Passe-Partout	PAG. M.83
Tritone	PAG. M.85
Domino	PAG. M.89

GLASS FRAME SYSTEM:

Seattle	PAG. M.93
Chicago	PAG. M.97

MANIGLIE / HANDLES:

Aurelia	PAG. M.107
Appia	PAG. M.111
Shore	PAG. M.115

APPENDIABITI / HOOKS:

Trama	PAG. M.121
Caligola	PAG. M.125



MANIGLIE

HANDLES

ALU *news* CONCEPT



M.10

AQUA

DESIGN: MARCO BORTOLIN



Maniglia a ponte modulare / Modular pull handle

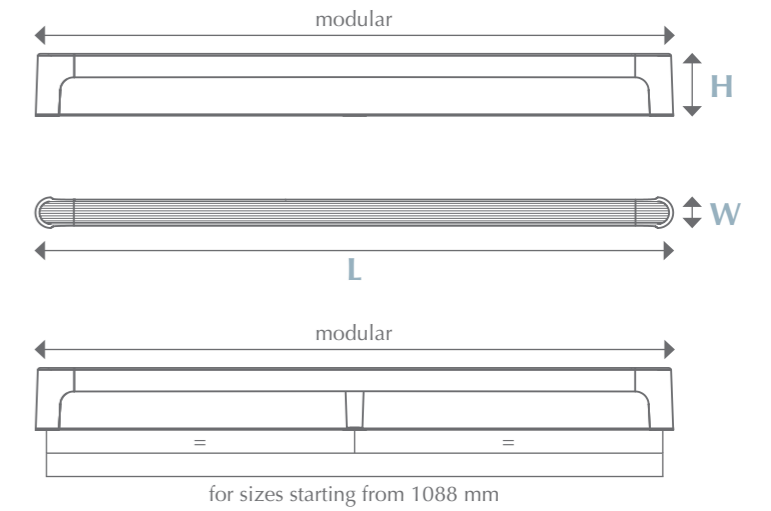
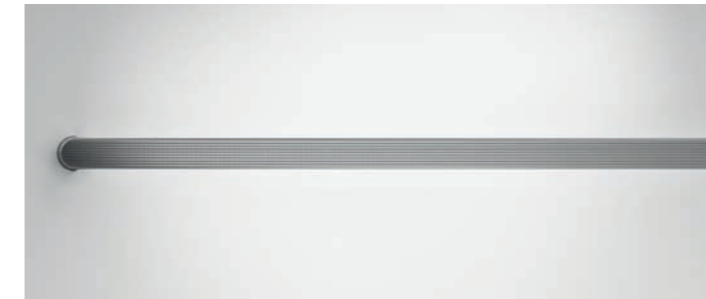

Codice Code	Interasse CtoC	Ingombro Overall Size	Altezza Height
16253A04800	480	L. 498 x W. 18	H. 37
16253A06400	640	L. 658 x W. 18	H. 37
16253A08000	800	L. 818 x W. 18	H. 37
16253A10880	1088	L. 1106 x W. 18	H. 37
16253A12000	1200	L. 1218 x W. 18	H. 37

Personalizzabile / Customizable
 Materiale / Material: ALLUMINIO - ZAMA / ALUMINIUM - ZAMAK

M.11

Finitura / Finish: T3 - Verde Malachite Silk Effect



M.12

Finitura / Finish: HA - Ardesia



M.13



M.14



M.15



AQUA-RAMA

DESIGN: MARCO BORTOLIN

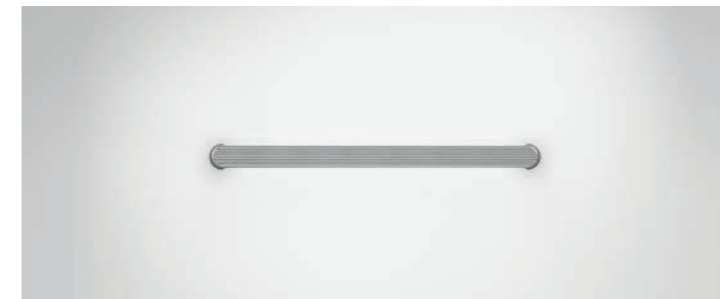
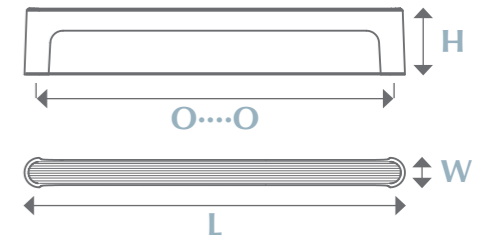

15253Z1600M

L. 173 W. 13 H. 30
O...O 160



15253Z3200M

L. 333 W. 13 H. 30
O...O 320

Finiture illustrate / Illustrated finishes:
REALIZZABILI IN TUTTE LE FINITURE MARELLA
DESIGN / AVAILABLE IN ALL ROBERTO MARELLA
STANDARD FINISHES

Materiale / Material: ZAMA / ZAMAK

Finitura / Finish: T1 - Tortora Silk



M.18

Finitura / Finish: 97 - Nickel opaco verniciato / Mat nickel painted



M.19

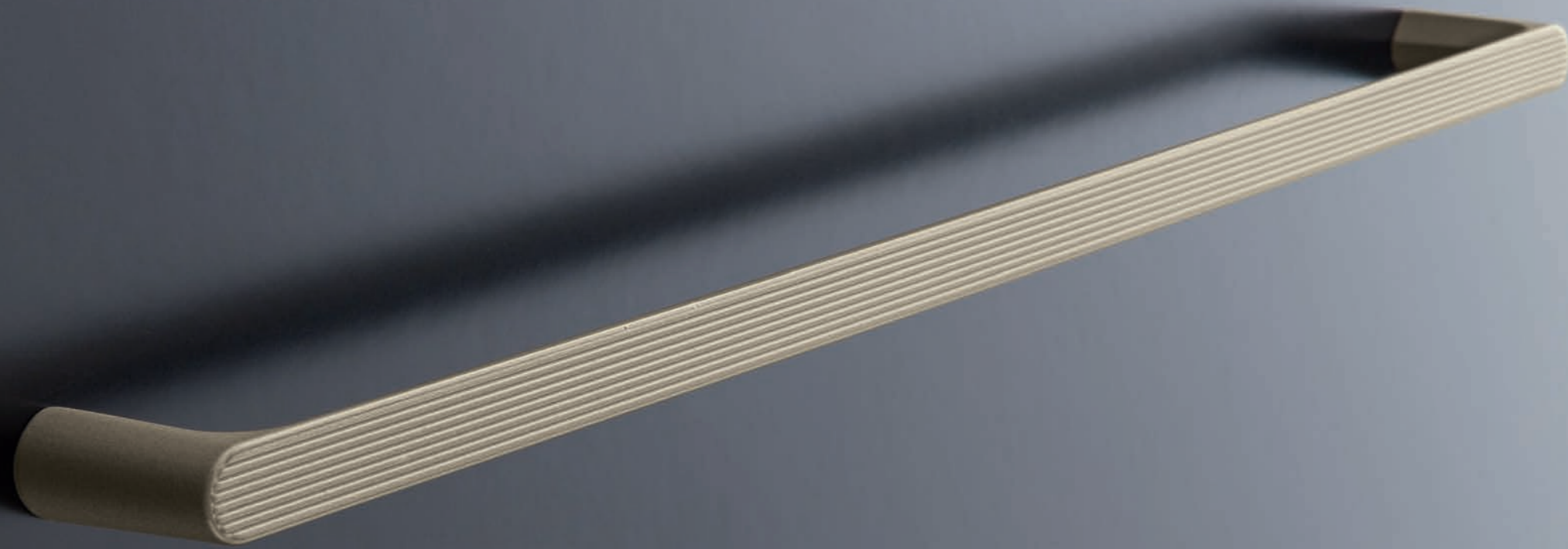

AQUA-RAMA

DESIGN: MARCO BORTOLIN

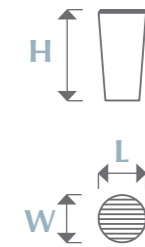

24253Z0120M

L. 12 W. 12 H. 24

Finiture illustrate / **I**llustrated finishes:
REALIZZABILI IN TUTTE LE FINITURE MARELLA
DESIGN / AVAILABLE IN ALL ROBERTO MARELLA
STANDARD FINISHES

Materiale / **M**aterial: ZAMA / ZAMAK



RIVA

DESIGN: MARCO BORTOLIN



Maniglia a ponte modulare / Modular pull handle

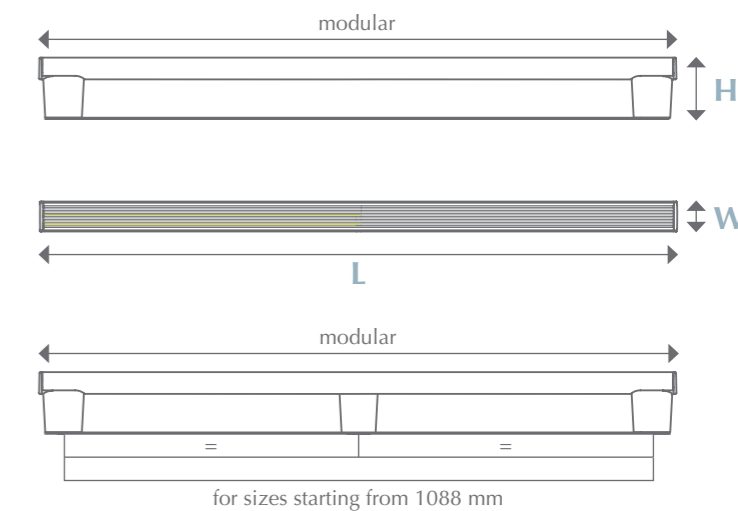
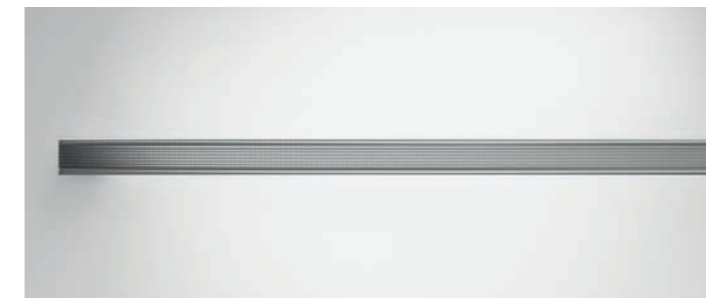

Codice Code	Interasse CtoC	Ingombro Overall Size	Altezza Height
16252A04800	480	L. 502 x W. 18	H. 36
16252A06400	640	L. 662 x W. 18	H. 36
16252A08000	800	L. 822 x W. 18	H. 36
16252A10880	1088	L. 1110 x W. 18	H. 36
16252A12000	1200	L. 1222 x W. 18	H. 36

Personalizzabile / Customizable

Materiale / Material: ALLUMINIO - ZAMA / ALUMINIUM - ZAMAK



M.26



M.27



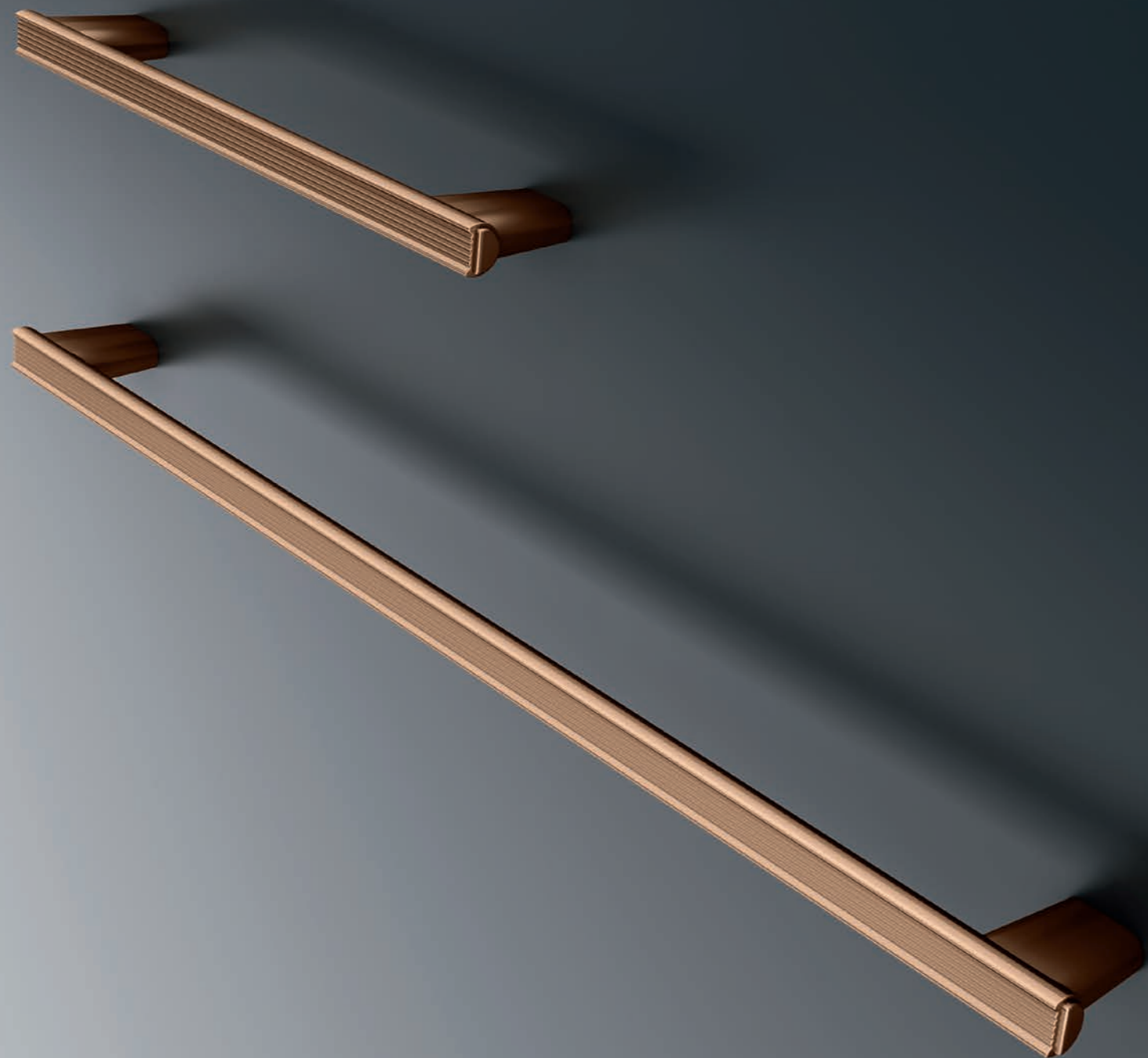

M.30

RIVA-RAMA

DESIGN: MARCO BORTOLIN

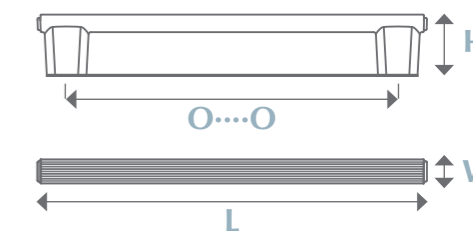

15252Z1600M

L. 177 W. 11 H. 28
O...O 160



15252Z3200M

L. 337 W. 11 H. 28
O...O 320

Finiture illustrate / Illustrated finishes:
REALIZZABILI IN TUTTE LE FINITURE MARELLA
DESIGN / AVAILABLE IN ALL ROBERTO MARELLA
STANDARD FINISHES

Materiale / Material: ZAMA / ZAMAK

M.31



M.32



M.33

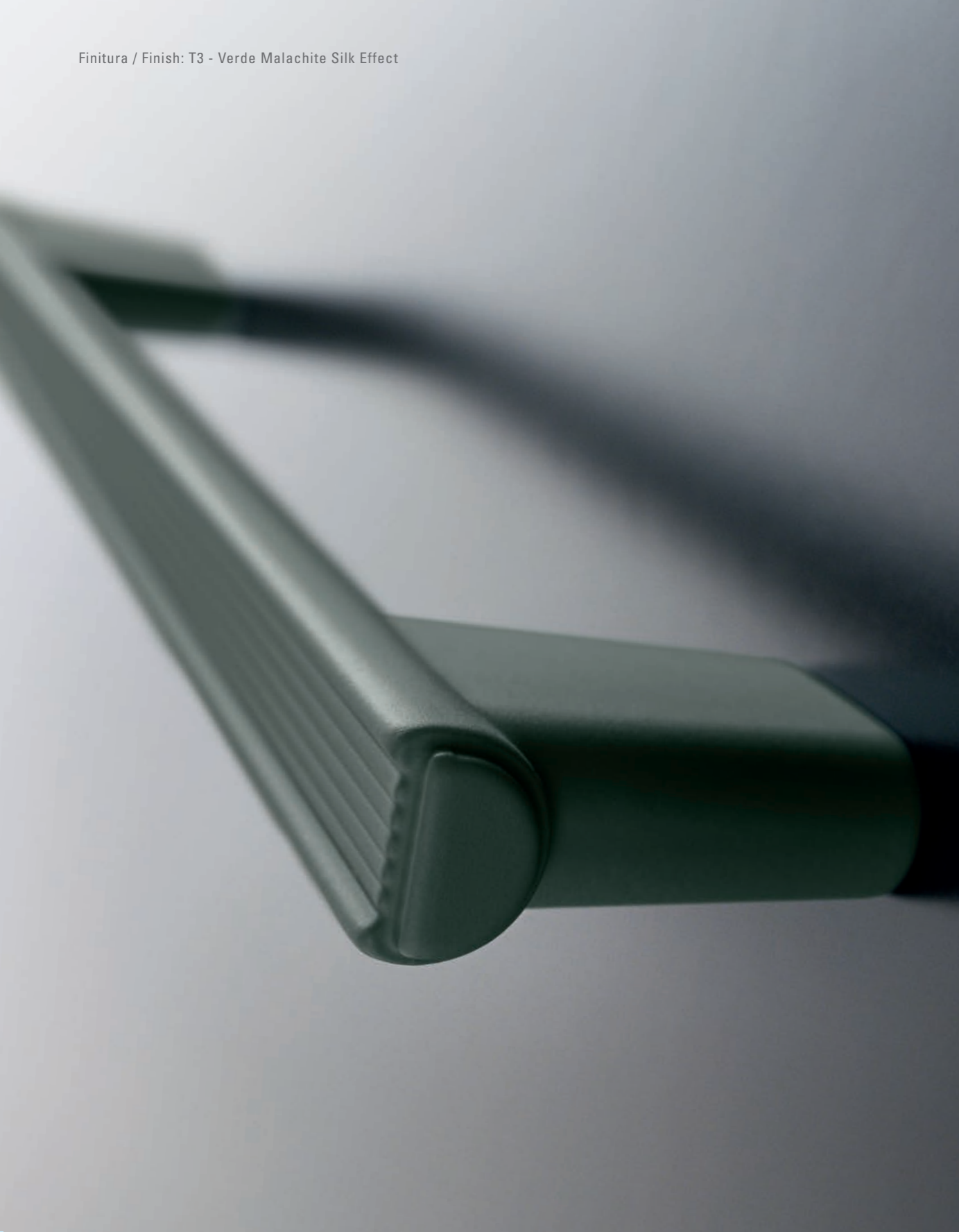

M.34



M.35



RIVA-RAMA

DESIGN: MARCO BORTOLIN

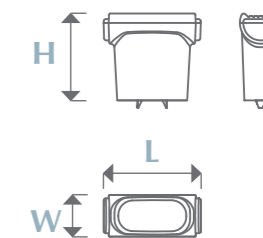

24252Z0260M

L. 26 W. 11 H. 23

Finiture illustrate / Illustrated finishes:
REALIZZABILI IN TUTTE LE FINITURE MARELLA
DESIGN / AVAILABLE IN ALL ROBERTO MARELLA
STANDARD FINISHES

Materiale / Material: ZAMA / ZAMAK



STILO

DESIGN: MARELLA DESIGN LAB

Maniglia a ponte modulare / Modular pull handle

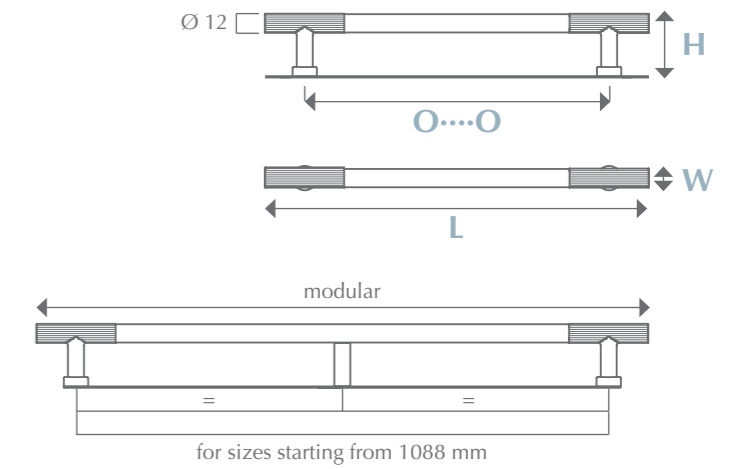

Codice Code	Interasse CtoC	Ingombro Overall Size	Altezza Height
16254A04800	480	L. 532 x W. 16	H. 39
16254A06400	640	L. 692 x W. 16	H. 39
16254A08000	800	L. 852 x W. 16	H. 39
16254A10880	1088	L. 1140 x W. 16	H. 39
16254A12000	1200	L. 1252 x W. 16	H. 39

Personalizzabile / Customizable
Materiale / Material: ALLUMINIO - ZAMA / ALUMINIUM - ZAMAK

Finitura / Finish: DH - Golden Shadow

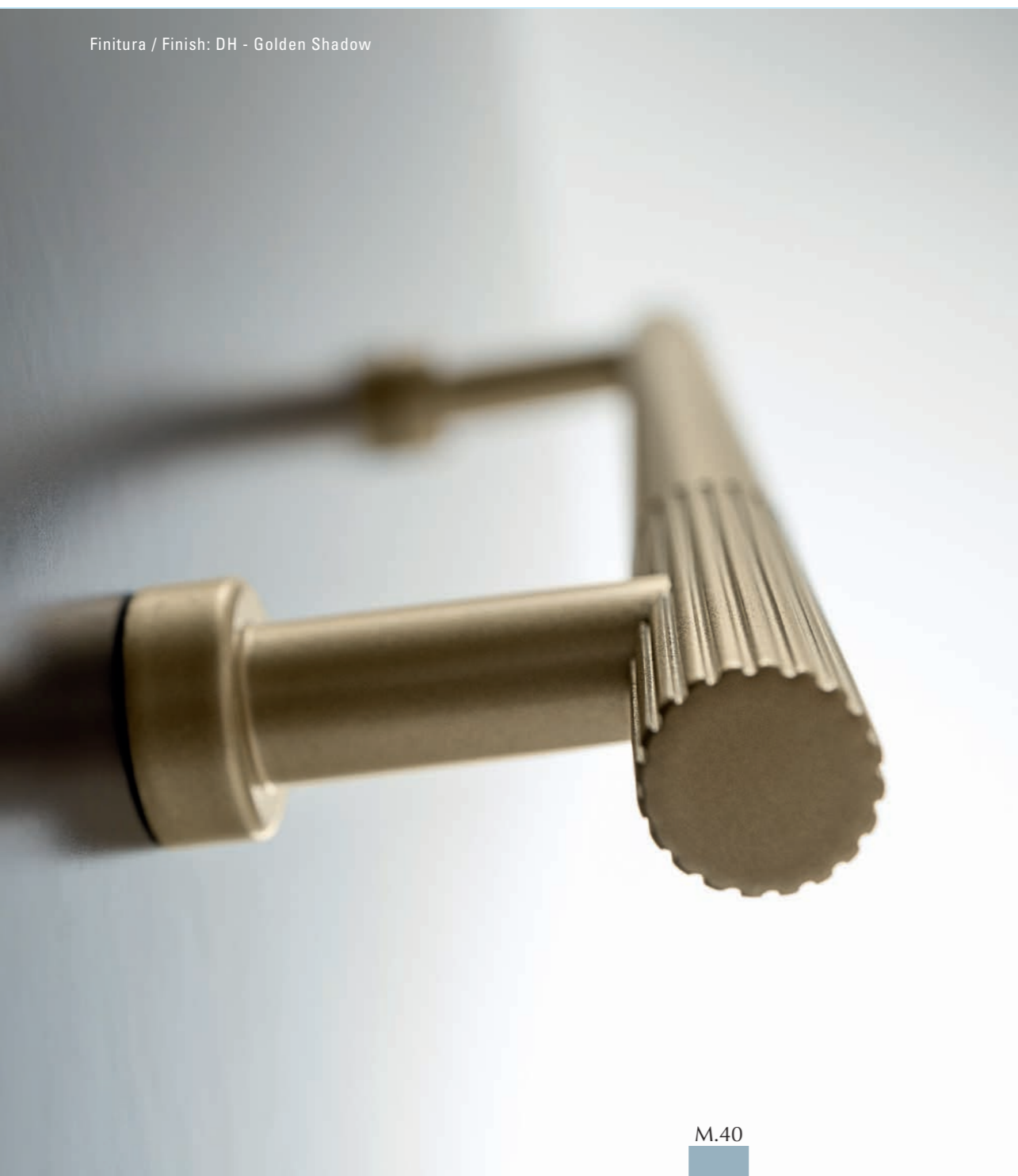

M.40

Finitura / Finish: T5 - Nero Silk Effect



M.41

Finitura / Finish: V3 - Bronze



M.42

Finitura / Finish: T5 - Nero Silk Effect



M.43



TRAMA+

DESIGN: MARCO BORTOLIN

Maniglia a ponte modulare / Modular pull handle

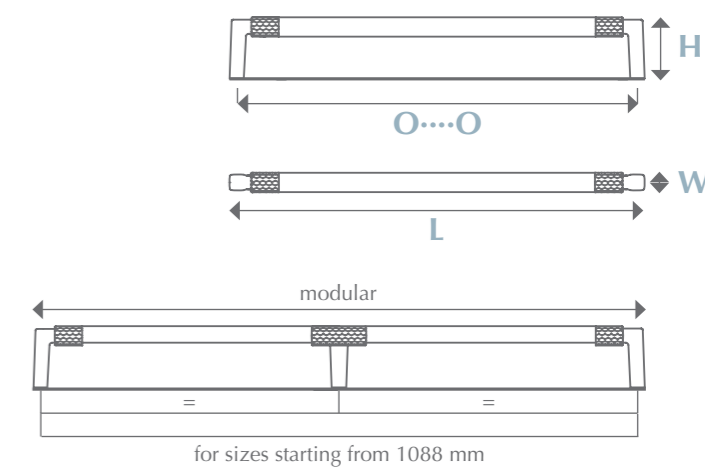

Codice Code	Interasse CtoC	Ingombro Overall Size	Altezza Height
16191A04800	480	L. 490 x W. 12	H. 38
16191A06400	640	L. 650 x W. 12	H. 38
16191A08000	800	L. 810 x W. 12	H. 38
16191A10880	1088	L. 1098 x W. 12	H. 38
16191A12000	1200	L. 1210 x W. 12	H. 38

Personalizzabile / Customizable

Materiale / Material: ALLUMINIO - ZAMA / ALUMINIUM - ZAMAK

Finitura / Finish: V2 - Ardesia Shimmer



M.46

Finitura / Finish: V2 - Ardesia Shimmer



M.47



TRAMA

DESIGN: MARCO BORTOLIN

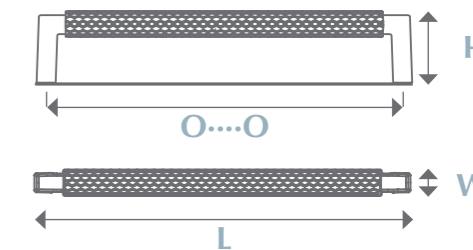

15191Z1600M

L. 168 W. 12 H. 33
O...O 160



15191Z3200M

L. 328 W. 12 H. 33
O...O 320

Finiture illustrate / Illustrated finishes:
 REALIZZABILI IN TUTTE LE FINITURE MARELLA
 DESIGN / AVAILABLE IN ALL ROBERTO MARELLA
 STANDARD FINISHES

Materiale / Material: ZAMA / ZAMAK



M.51



M.50

TRAMA

DESIGN: MARCO BORTOLIN

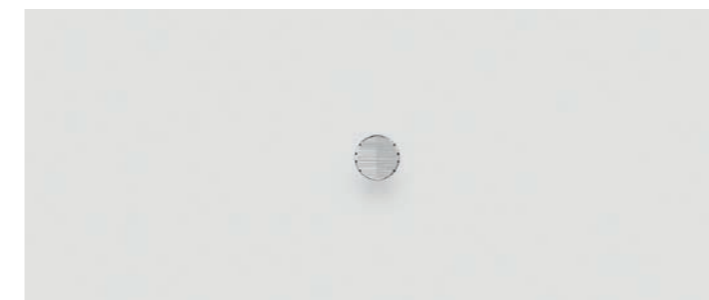

24191Z0150M

L. 15 W. 15 H. 33

Finiture illustrate / Illustrated finishes:
REALIZZABILI IN TUTTE LE FINITURE MARELLA
DESIGN / AVAILABLE IN ALL ROBERTO MARELLA
STANDARD FINISHES

Materiale / Material: ZAMA / ZAMAK



DROP

DESIGN: MARELLA DESIGN LAB

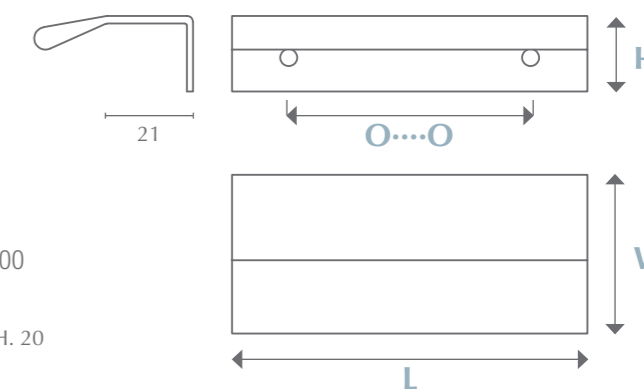

Maniglia modulare / Modular handle



16016A00900

L. 94 W. 42 H. 20
O...O 64



16016A01900

L. 190 W. 42 H. 20
O...O 160

Personalizzabile / Customizable
Materiale / Material: ALLUMINIO / ALUMINIUM

Finitura / Finish: DS - Ottone / Brass



M.56



Finitura / Finish: T8 - Cacao Silk Effect



M.57



SQUARE

DESIGN: MARELLA DESIGN LAB

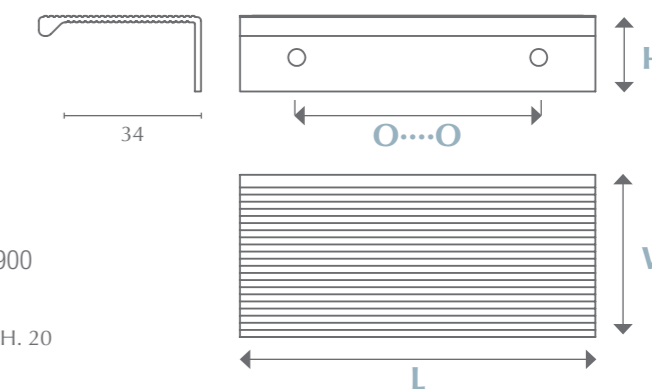

Maniglia modulare / Modular handle



16013A00900

L. 94 W. 43 H. 20
O...O 64

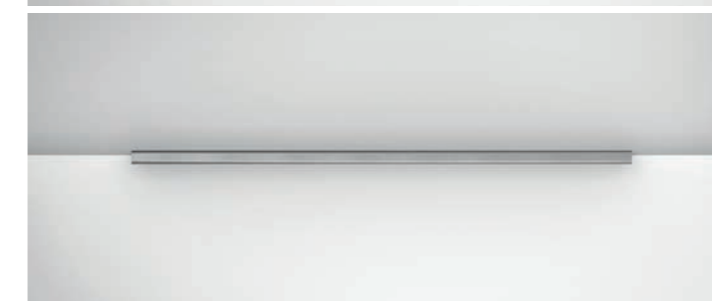

16013A01900

L. 190 W. 43 H. 20
O...O 160

Personalizzabile / Customizable
Materiale / Material: ALLUMINIO / ALUMINIUM

LINE

DESIGN: MARELLA DESIGN LAB

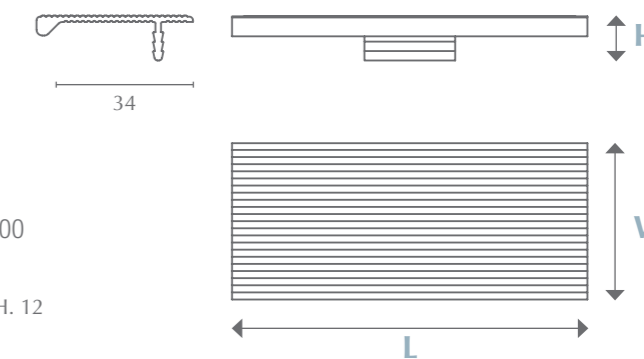

Maniglia modulare / Modular handle

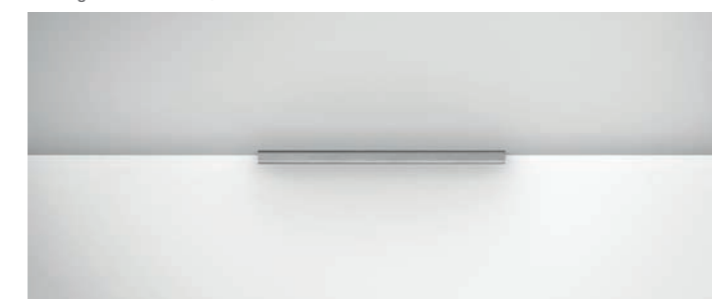

16014A00900

L. 94 W. 41 H. 12

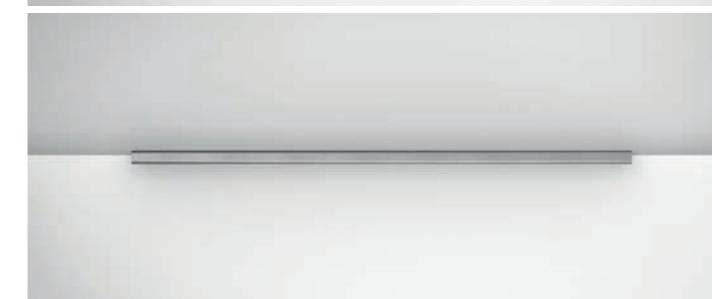

16014A01900

L. 190 W. 41 H. 12

Personalizzabile / Customizable
Materiale / Material: ALLUMINIO / ALUMINIUM

FLORIDA

COMBINAZIONI / COMBINATIONS

Maniglie integrate modulari / Modular integrated handles



MANIGLIA / HANDLE **FLORIDA**



MANIGLIA / HANDLE **FLORIDA**

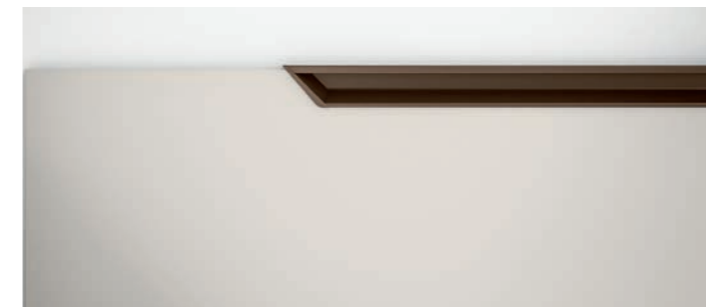

MANIGLIA / HANDLE **FLORIDA-0 SX / LEFT**

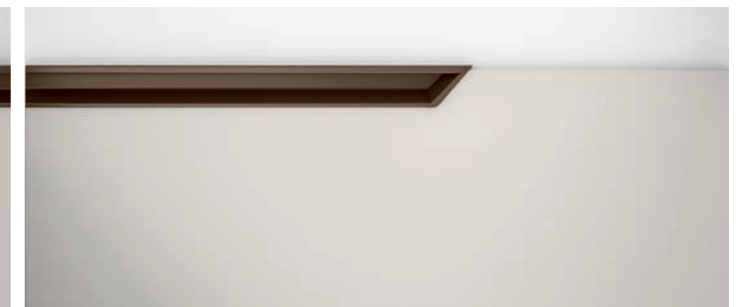

MANIGLIA / HANDLE **FLORIDA-0 DX / RIGHT**

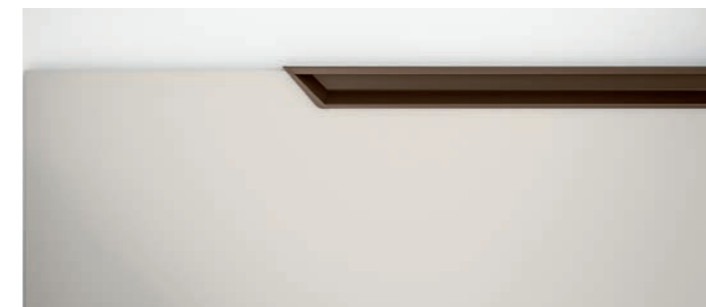

MANIGLIA / HANDLE **FLORIDA-0 SX / LEFT**



MANIGLIA / HANDLE **PASSANTE**

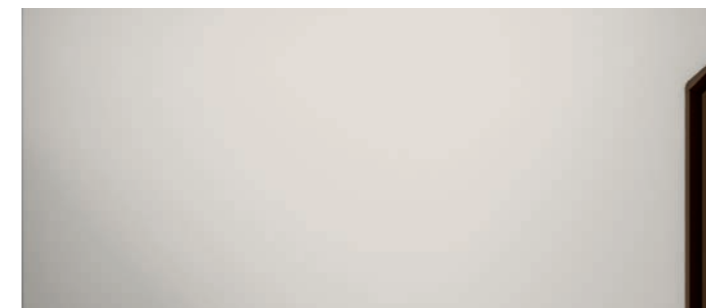

MANIGLIA / HANDLE **FLORIDA-0 SX / LEFT**

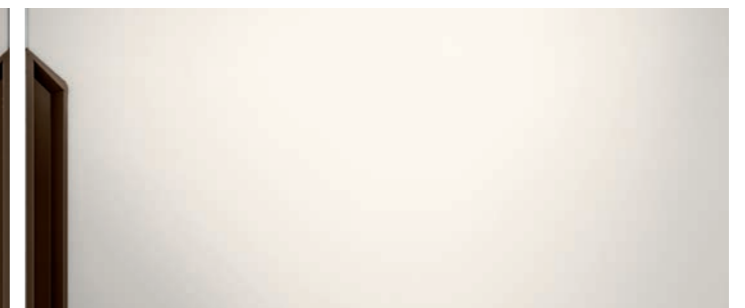

MANIGLIA / HANDLE **FLORIDA-0 DX / RIGHT**

FLORIDA

DESIGN: MARCO BORTOLIN

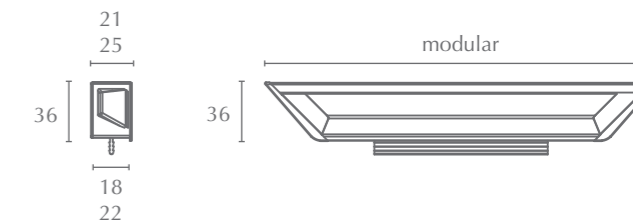

Maniglia integrata modulare / Modular integrated handle



Codice Code	Lunghezza Length (mm)	Spessore Thickness (mm)	Spessore anta Door thickness (mm)	Altezza Height (mm)
16031A03800	380	21	18	36
16031A10880	1088	21	18	36
16026A03800	380	25	22	36
16026A10880	1088	25	22	36

Personalizzabile / Customizable
Materiale / Material: ALLUMINIO - ZAMA / ALUMINIUM - ZAMAK

FLORIDA-O

DESIGN: MARCO BORTOLIN

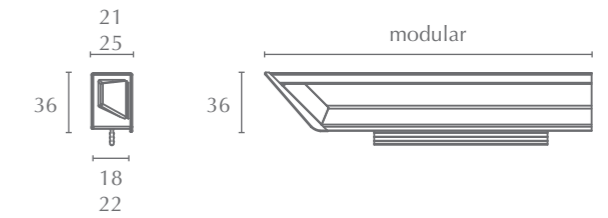

Maniglia integrata modulare / Modular integrated handle



MANIGLIA / HANDLE **FLORIDA-O** SX / LEFT



MANIGLIA / HANDLE **FLORIDA-O** DX / RIGHT

Codice Code	Lunghezza Length (mm)	Spessore Thickness (mm)	Spessore anta Door thickness (mm)	Altezza Height (mm)
16027A02000 (DX)	200	25	22	36
16027A03800 (DX)	380	25	22	36
16028A02000 (SX)	200	25	22	36
16028A03800 (SX)	380	25	22	36
16032A02000 (DX)	200	21	18	36
16032A03800 (DX)	380	21	18	36
16033A02000 (SX)	200	21	18	36
16033A03800 (SX)	380	21	18	36

Personalizzabile / Customizable

Materiale / Material: ALLUMINIO - ZAMA / ALUMINIUM - ZAMAK

FLORIDA-O

DESIGN: MARCO BORTOLIN

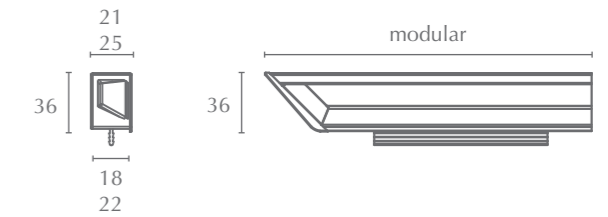

Maniglia integrata modulare / Modular integrated handle



MANIGLIA / HANDLE **FLORIDA-O** SX / LEFT

MANIGLIA / HANDLE **FLORIDA-O** DX / RIGHT

Codice Code	Lunghezza Length (mm)	Spessore Thickness (mm)	Spessore anta Door thickness (mm)	Altezza Height (mm)
16027A10880 (DX)	1088	25	22	36
16027A12000 (DX)	1200	25	22	36
16028A10880 (SX)	1088	25	22	36
16028A12000 (SX)	1200	25	22	36
16032A10880 (DX)	1088	21	18	36
16032A12000 (DX)	1200	21	18	36
16033A10880 (SX)	1088	21	18	36
16033A12000 (SX)	1200	21	18	36

Personalizzabile / Customizable

Materiale / Material: ALLUMINIO - ZAMA / ALUMINIUM - ZAMAK



RETTA

COMBINAZIONI / COMBINATIONS

Maniglie integrate modulari / Modular integrated handles



MANIGLIA / HANDLE **RETTA**



MANIGLIA / HANDLE **RETTA**



MANIGLIA / HANDLE **RETTA-0 SX** / LEFT



MANIGLIA / HANDLE **RETTA-0 DX** / RIGHT



MANIGLIA / HANDLE **RETTA-0 SX** / LEFT



MANIGLIA / HANDLE **PASSANTE**



MANIGLIA / HANDLE **RETTA-0 SX** / LEFT



MANIGLIA / HANDLE **RETTA-0 DX** / RIGHT

RETTA

DESIGN: MARCO BORTOLIN

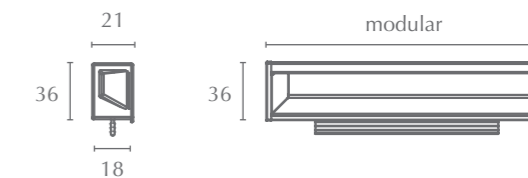

Maniglia integrata modulare / Modular integrated handle



Codice Code	Lunghezza Length (mm)	Spessore Thickness (mm)	Spessore anta Door thickness (mm)	Altezza Height (mm)
16023A02000	200	21	18	36
16023A03800	380	21	18	36
16023A10880	1088	21	18	36

Personalizzabile / Customizable
Materiale / Material: ALLUMINIO - ZAMA / ALUMINIUM - ZAMAK



M.74

RETTA-O

DESIGN: MARCO BORTOLIN

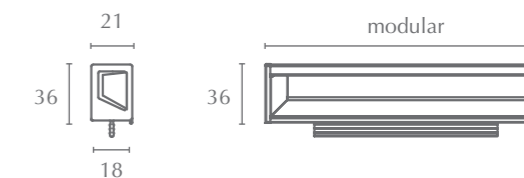

Maniglia integrata modulare / Modular integrated handle



MANIGLIA / HANDLE **RETTA-O** SX / LEFT



MANIGLIA / HANDLE **RETTA-O** DX / RIGHT

Codice Code	Lunghezza Length (mm)	Spessore Thickness (mm)	Spessore anta Door thickness (mm)	Altezza Height (mm)
16024A02000 (DX)	200	21	18	36
16024A03800 (DX)	380	21	18	36
16025A02000 (SX)	200	21	18	36
16025A03800 (SX)	380	21	18	36

Personalizzabile / Customizable

Materiale / Material: ALLUMINIO - ZAMA / ALUMINIUM - ZAMAK

M.75

RETTA-O

DESIGN: MARCO BORTOLIN

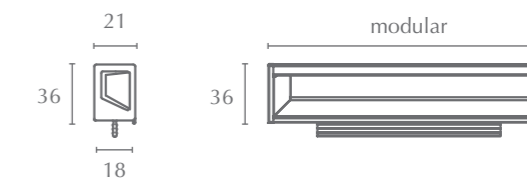

Maniglia integrata modulare / Modular integrated handle



MANIGLIA / HANDLE **RETTA-O** SX / LEFT

MANIGLIA / HANDLE **RETTA-O** DX / RIGHT

Codice Code	Lunghezza Length (mm)	Spessore Thickness (mm)	Spessore anta Door thickness (mm)	Altezza Height (mm)
16024A10880 (DX)	1088	21	18	36
16024A12000 (DX)	1200	21	18	36
16025A10880 (SX)	1088	21	18	36
16025A12000 (SX)	1200	21	18	36

Personalizzabile / Customizable

Materiale / Material: ALLUMINIO - ZAMA / ALUMINIUM - ZAMAK

PASSANTE

DESIGN: MARCO BORTOLIN

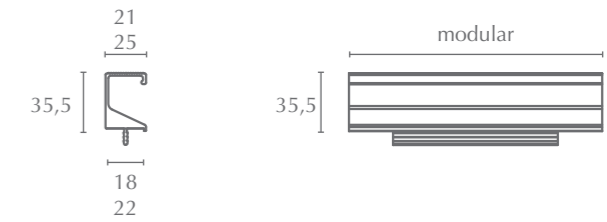

Maniglia integrata modulare / Modular integrated handle



Codice Code	Lunghezza Length (mm)	Spessore Thickness (mm)	Spessore anta Door thickness (mm)	Altezza Height (mm)
16022A04470	447	25	22	35,5
16022A05970	597	25	22	35,5
16022A08970	897	25	22	35,5
16022A11970	1197	25	22	35,5
16030A04470	447	21	18	35,5
16030A05970	597	21	18	35,5
16030A08970	897	21	18	35,5
16030A11970	1197	21	18	35,5

Finitura / Finish: V1 - Black Shimmer



PASSANTE + PASSANTE

M.80

PASSANTE



COMBINAZIONI / COMBINATIONS

PASSANTE +
FLORIDA-O (DX E SX)



PASSANTE +
RETTA-O (DX E SX)



M.81

PASSE-PARTOUT



BARRA E TAPPI DI CHIUSURA / BAR & END CAPS

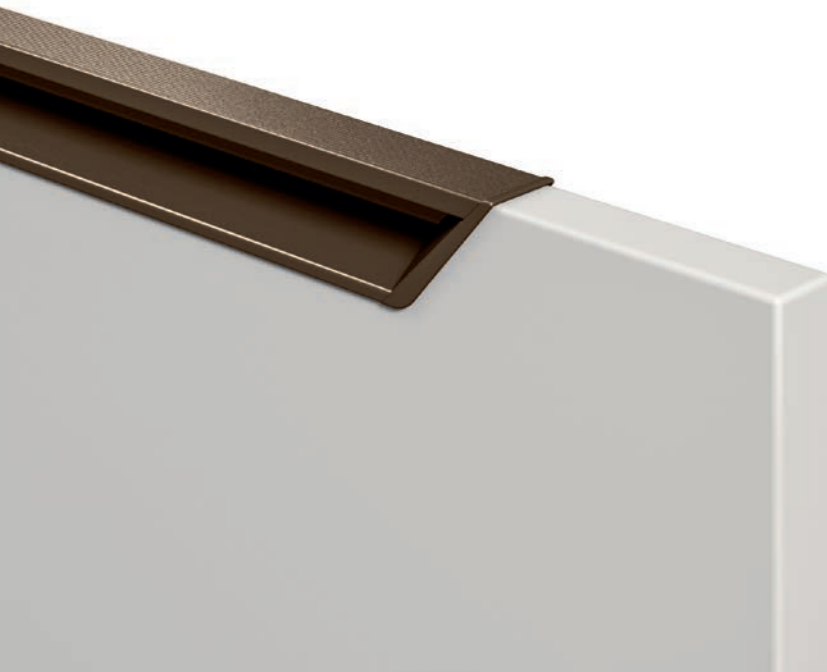
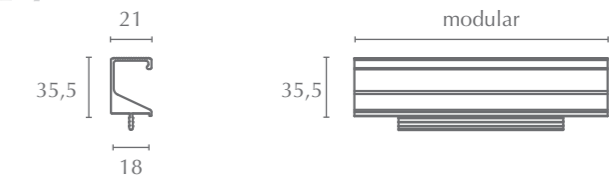

17031Z03602
CUP 45° SX



17031Z03601
CUP 45° DX

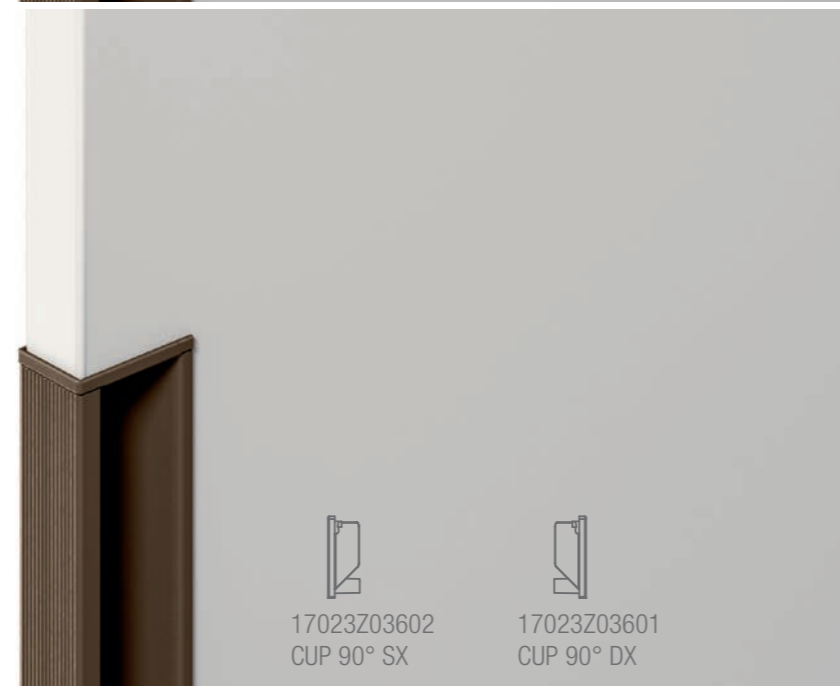

17023Z03602
CUP 90° SX



17023Z03601
CUP 90° DX

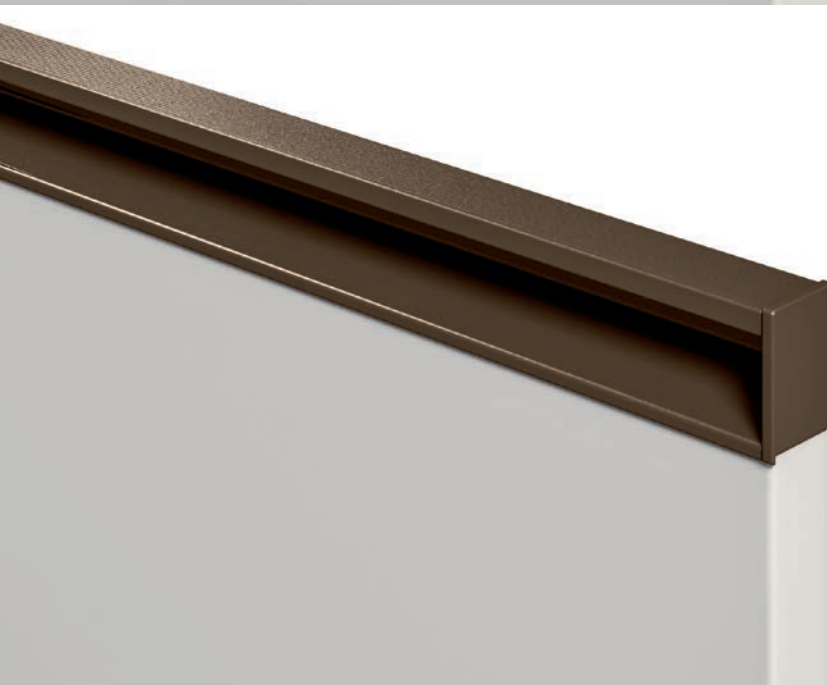

17024Z03602
END CUP 90° SX



17024Z03601
END CUP 90° DX



Codice Code	Lunghezza Length (mm)	Spessore Thickness (mm)	Spessore anta Door thickness (mm)	Altezza Height (mm)
16029A30000	3000	21	18	35,5

M.82

M.83

Personalizzabile / Customizable

Materiale / Material: ALLUMINIO - ZAMA / ALUMINIUM - ZAMAK



TRITONE

DESIGN: MARCO BORTOLIN

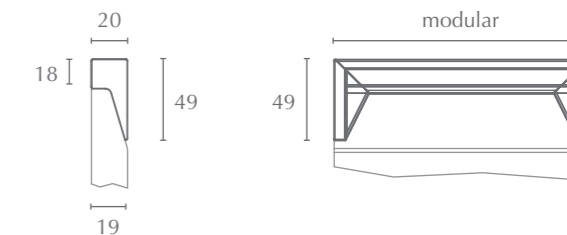

Maniglia integrata modulare / Modular integrated handle



Codice Code	Lunghezza Length (mm)	Spessore Thickness (mm)	Spessore anta Door thickness (mm)	Altezza Height (mm)
16034A04470	447	20	19	49
16034A05970	597	20	19	49
16034A08970	897	20	19	49
16034A11970	1197	20	19	49

Personalizzabile / Customizable
Materiale / Material: ALLUMINIO - ZAMA / ALUMINIUM - ZAMAK



M.86



M.87

DOMINO

DESIGN: MARCO BORTOLIN

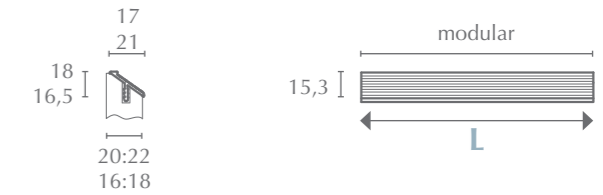

Maniglia integrata modulare / Modular integrated handle



Codice Code	Lunghezza Length (mm)	Spessore Thickness (mm)	Spessore anta Door thickness (mm)	Altezza Height (mm)
16035A04470	447	17	16 : 18	16,5
16035A05970	597	17	16 : 18	16,5
16035A08970	897	17	16 : 18	16,5
16035A11970	1197	17	16 : 18	16,5
16019A04470	447	21	20 : 22	18
16019A05970	597	21	20 : 22	18
16019A08970	897	21	20 : 22	18
16019A11970	1197	21	20 : 22	18

Personalizzabile / Customizable
Materiale / Material: ALLUMINIO - ZAMA / ALUMINIUM - ZAMAK

GLASS FRAME SYSTEM



GLASS FRAME SYSTEM



M.90

ALU *news* CONCEPT



SEATTLE

DESIGN: MARCO BORTOLIN

Telaio anta vetro / Glass frame Systems

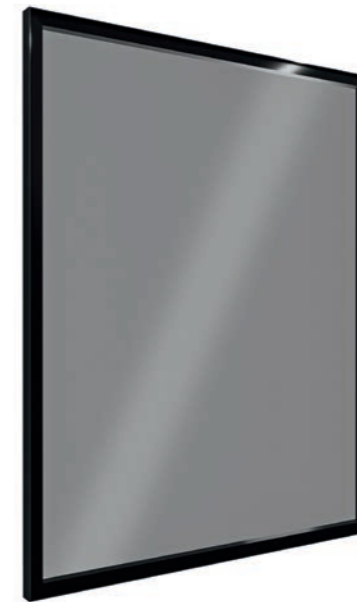

SEATTLE Profilo senza maniglia / No handle frame		
Modello profilo / Frame model	Tipo di cerniera / Hinge model	Kit per Assemblaggio / Assembly kit
SEATTLE - 5001	Per cerniere a testa ovale Ideal for Oval head hinges	Code: 661.999.130 Viteria + 4 squadrette standard Screws + 4 standard brackets
SEATTLE - 5002	Per cerniere Up&Down Ideal for Up&Down hinges	Code: 661.999.131 Viteria + 2 squadrette standard + 2 squadrette per cerniera Up&Down Screws + 2 sandard brackets + 2 brackets for Up&Down hinges

Finitura / Finish: V1 - Black Shimmer



M.94

Finitura / Finish: V2 - Ardesia Shimmer



M.95



M.96

CHICAGO

DESIGN: MARCO BORTOLIN

Telaio anta vetro / Glass frame Systems



CHICAGO Profilo con maniglia / Frame with handle		
Modello profilo / Frame model	Tipo di cerniera / Hinge model	Kit per Assemblaggio / Assembly kit
CHICAGO - 5001	Per cerniere a testa ovale Ideal for Oval head hinges	Code: 661.999.130 Viteria + 4 squadrette standard Screws + 4 standard brackets
CHICAGO - 5002	Per cerniere Up&Down Ideal for Up&Down hinges	Code: 661.999.131 Viteria + 2 squadrette standard + 2 squadrette per cerniera Up&Down Screws + 2 sandard brackets + 2 brackets for Up&Down hinges

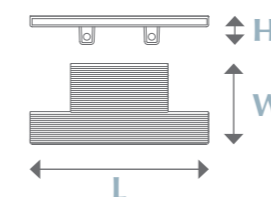

17001Z08800

L. 88 W. 40 H. 14

M.97

Finitura / Finish: V4 - Dark Bronze



Finitura / Finish: V1 - Black Shimmer



M.98



M.99



Finitura / Finish: V6 - Savannah



Finitura / Finish: V6 - Savannah



Finitura / Finish: V6 - Savannah



M.100

Finitura / Finish: V6 - Savannah



M.101

Finitura / Finish: V4 - Dark Bronze



M.102

Finitura / Finish: V6 - Savannah



Finitura / Finish: V4 - Dark Bronze



M.103

MANIGLIE

HANDLES

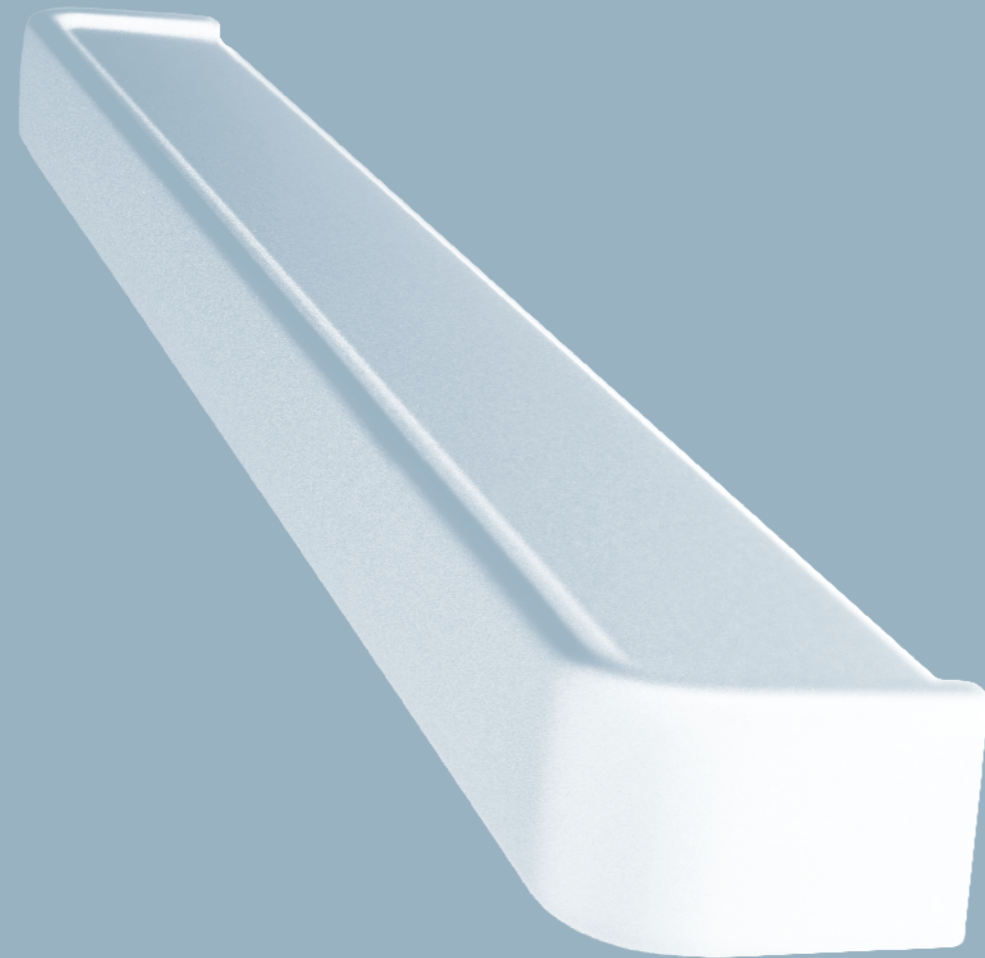

M.104

MODERNO



AURELIA

DESIGN: ALESSANDRO ELLI



Maniglia in Zama / Zamak handle



15273Z0960M

L. 111 W. 10 H. 17
O....O 096



15273Z1600M

L. 175 W. 12 H. 18
O....O 160

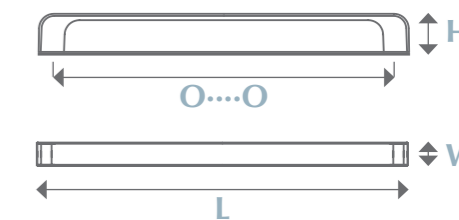

Finiture illustrate / Illustrated finishes:
REALIZZABILI IN TUTTE LE FINITURE MARELLA
DESIGN / AVAILABLE IN ALL ROBERTO MARELLA
STANDARD FINISHES

Materiale / Material: ZAMA / ZAMAK

Finitura / Finish: HC - Champagne



M.108

Finitura / Finish: T3 - Verde Malachite Silk Effect



M.109



APPIA

DESIGN: ALESSANDRO ELLI

Maniglia in Zama / Zamak handle



15274Z0960M

L. 110 W. 12 H. 18
O....O 096



15274Z1600M

L. 174 W. 14 H. 20
O....O 160

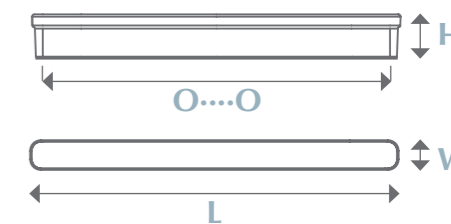

Finiture illustrate / **I**llustrated finishes:
REALIZZABILI IN TUTTE LE FINITURE MARELLA
DESIGN / AVAILABLE IN ALL ROBERTO MARELLA
STANDARD FINISHES

Materiale / **M**aterial: ZAMA / ZAMAK

Finitura / Finish: HB - Brown



M.112

Finitura / Finish: DF - Bright bronze



M.113

SHORE

DESIGN: MARELLA DESIGN LAB

Maniglia in Zama / Zamak handle



15240Z0960M

L. 133 W. 16 H. 17
O....O 096



15240Z1600M

L. 197 W. 16 H. 17
O....O 160

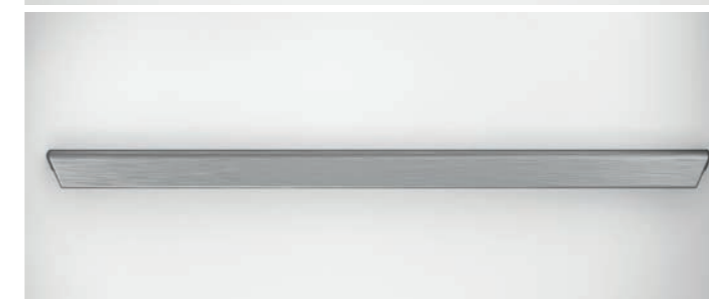

15240Z3200M

L. 357 W. 16 H. 17
O....O 320

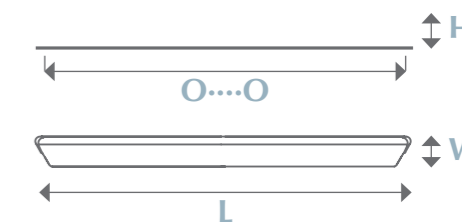

Finiture illustrate / Illustrated finishes:
REALIZZABILI IN TUTTE LE FINITURE MARELLA
DESIGN / AVAILABLE IN ALL ROBERTO MARELLA
STANDARD FINISHES

Materiale / Material: ZAMA / ZAMAK

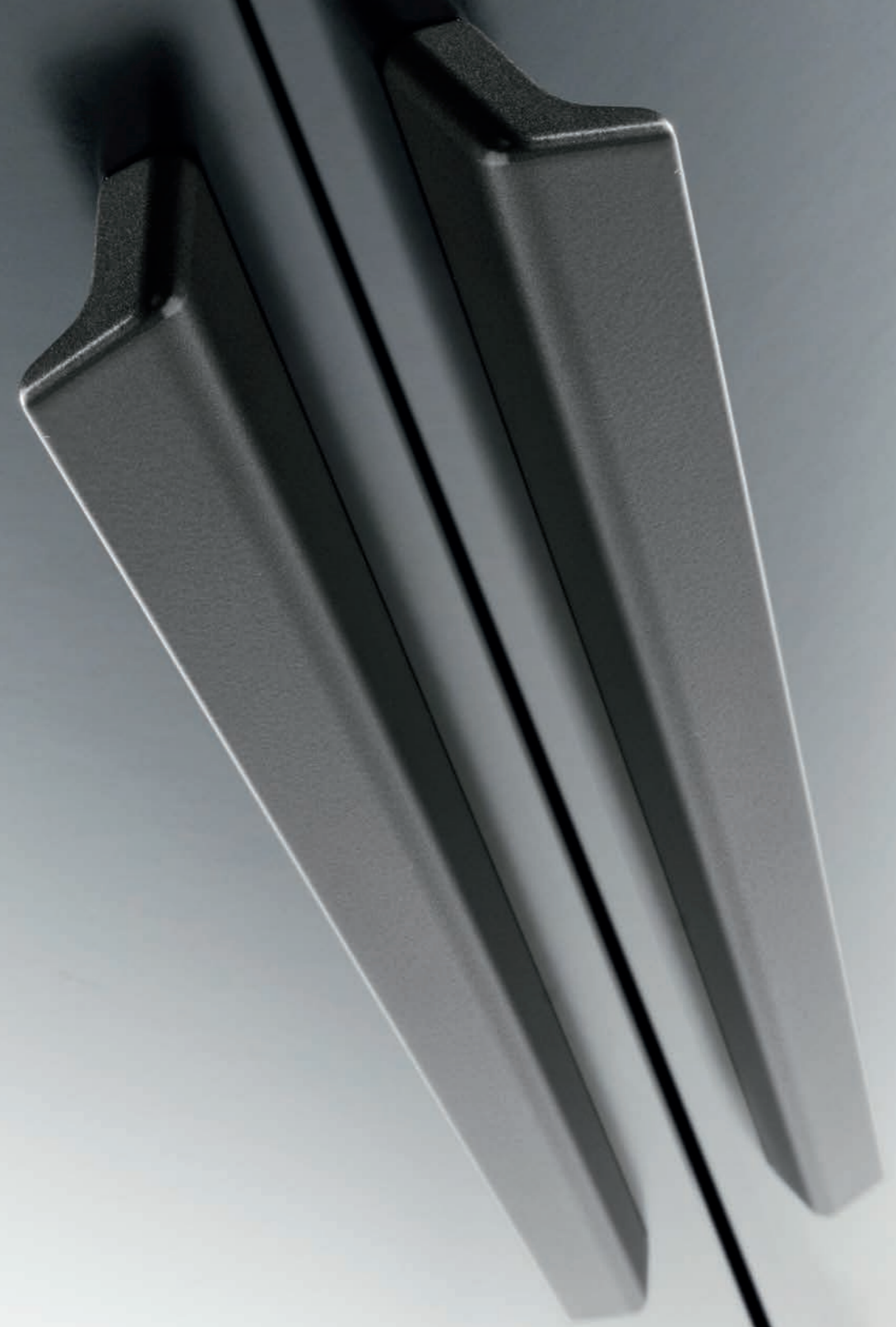

M.116



M.117

APPENDIABITI

HOOKS

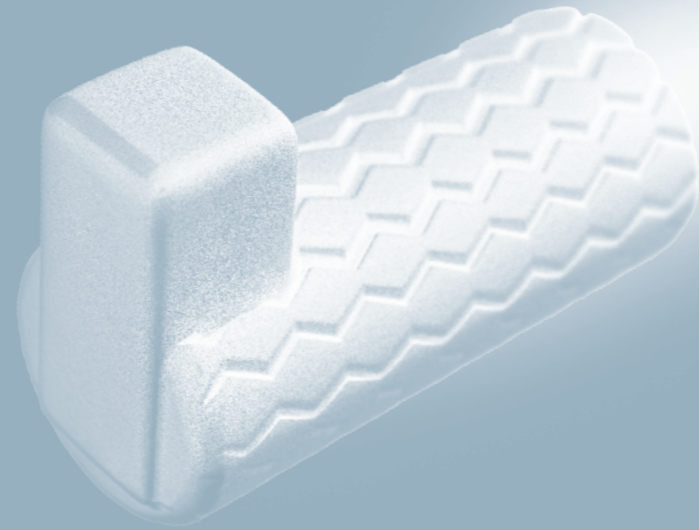

TRAMA

DESIGN: MARCO BORTOLIN

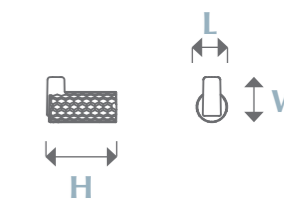

Appendiabiti in Zama / Zamak hook

43191Z0460M

L. 20 W. 30 H. 46



Finiture illustrate / **I**llustrated finishes:
REALIZZABILI IN TUTTE LE FINITURE MARELLA
DESIGN / AVAILABLE IN ALL ROBERTO MARELLA
STANDARD FINISHES

Materiale / **M**aterial: ZAMA / ZAMAK

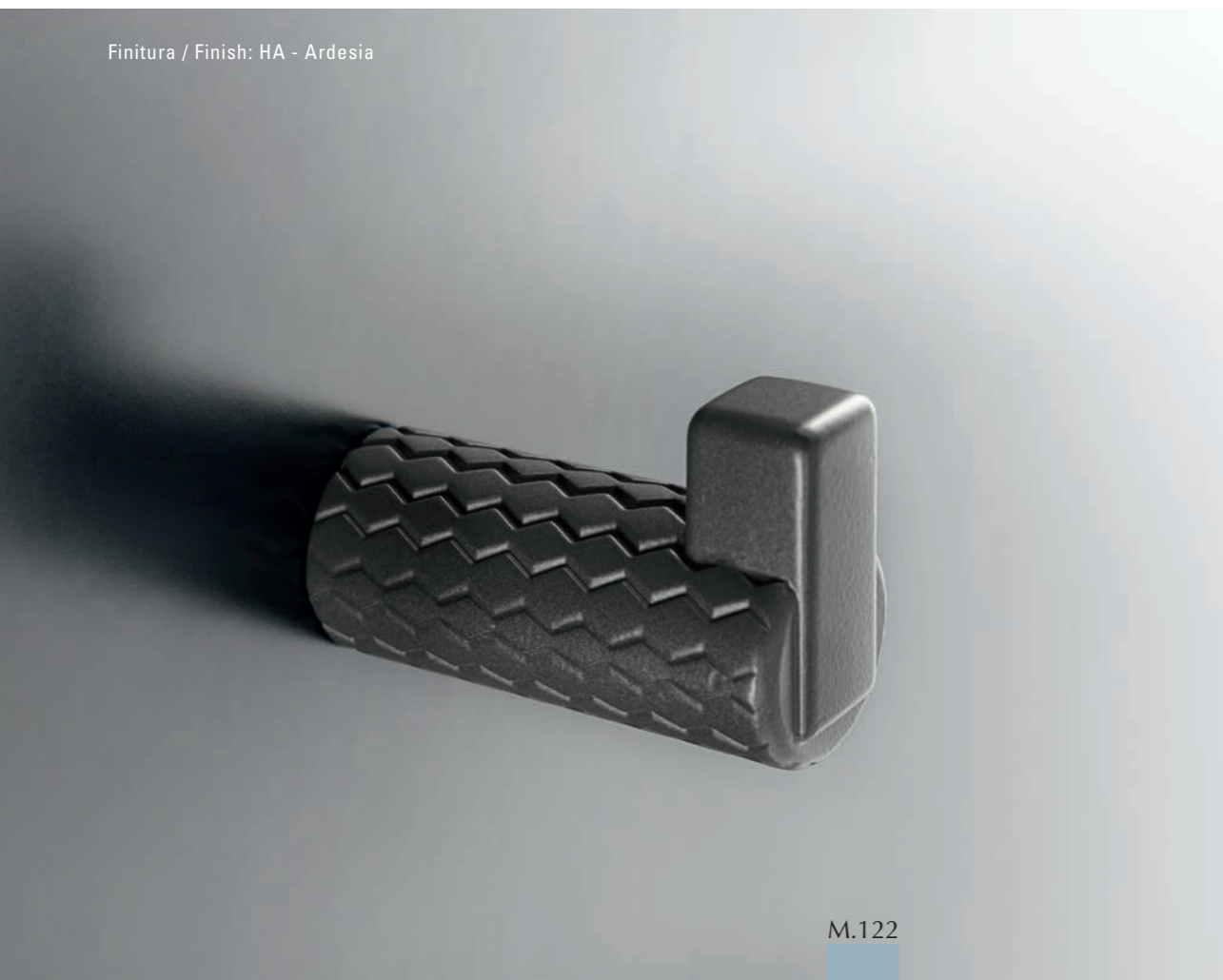

M.122

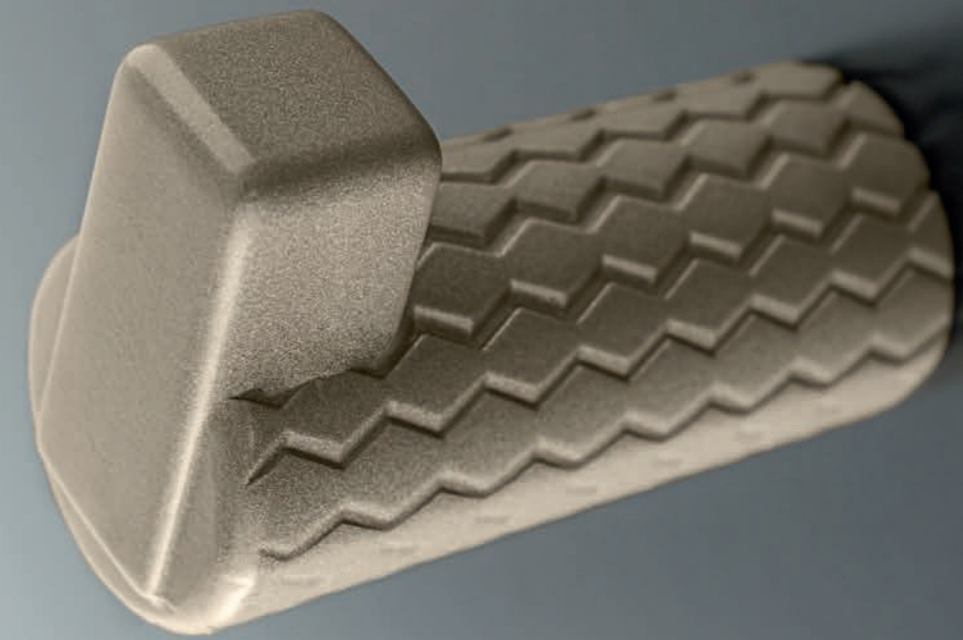

M.123



M.124

CALIGOLA

DESIGN: ALESSANDRO ELLI

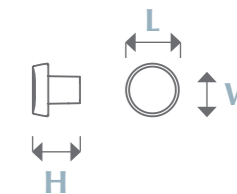

Appendiabiti in Zama / Zamak hook



43250Z0500M

L. 50 W. 50 H. 45

Finiture illustrate / Illustrated finishes:
REALIZZABILI IN TUTTE LE FINITURE MARELLA
DESIGN / AVAILABLE IN ALL ROBERTO MARELLA
STANDARD FINISHES

Materiale / Material: ZAMA / ZAMAK

M.125

Finitura / Finish: T6 - Bianco Silk Effect

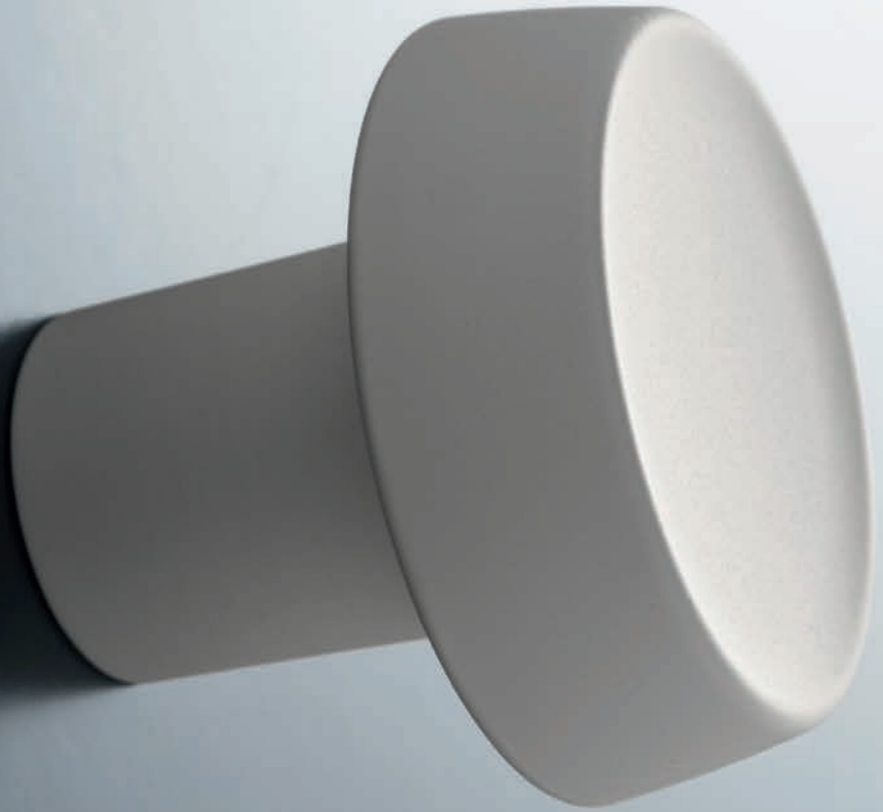

M.126

Finitura / Finish: T3 - Verde Malachite Silk Effect

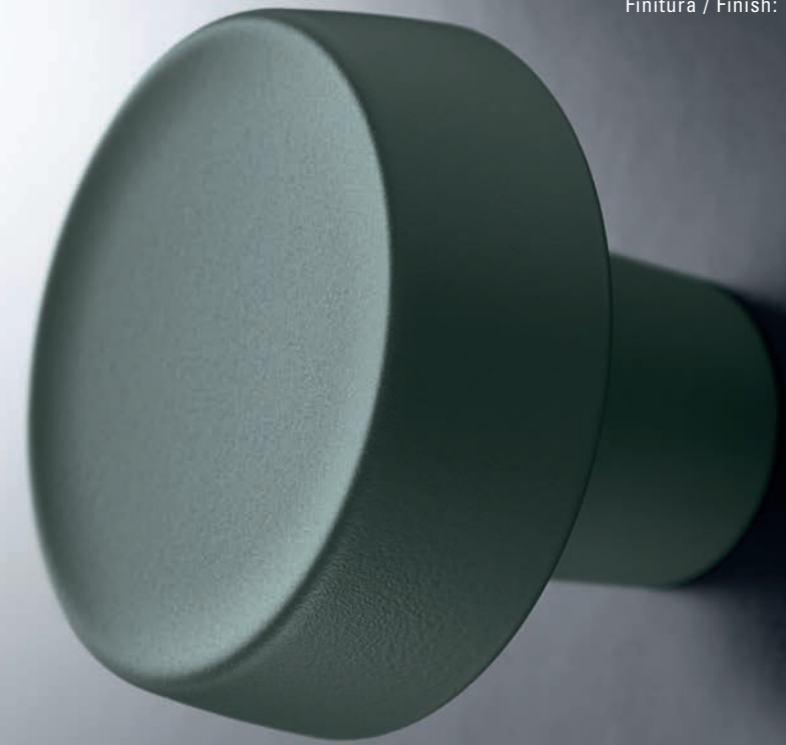

Finitura / Finish: T7 - Cool Grey Silk Effect



M.127

Collezione / Index Collections

*Rail
Neoclassico
Conchiglia*

*PAG. C131
PAG. C135
PAG. C139*



Contem poraneo

Rail

DESIGN: MARELLA DESIGN LAB



15250Z16000.32

24226Z03000.32

CODICE <i>Code</i>	MISURE <i>Overall size</i>	INTERASSE <i>C. to C.</i>
15250Z16000	195x19x36	160
24226Z03000	30x24	-



Neoclassico

Serie realizzabile in tutte le finiture indicate a catalogo / Series available in all finishes in the catalogue.

Finitura / Finish: 05 - Brunito / Burnished



15341Z25600.05



15341Z16000.05



15341.12800.05



15341.09600.05



15341.06400.05

CODICE <i>Code</i>	MISURE <i>Overall size</i>	INTERASSE <i>C. to C.</i>
15341Z25600	293x22	256
15341Z16000	195x21	160
15341.12800	162x21	128
15341.09600	130x20	96
15341.06400	98x20	64

C.136

Contemporaneo

Finitura / Finish: D0 - Watery Rust



Finitura / Finish: 19 - Similferro / Similiron

C.137

Contemporaneo



Conchiglia

DESIGN: MARELLA DESIGN LAB

Finitura / Finish: 09 - Florence



15264Z06400.09

CODICE
Code
15264Z06400

MISURE
Overall size
104x31x25

INTERASSE
C. to C.
064



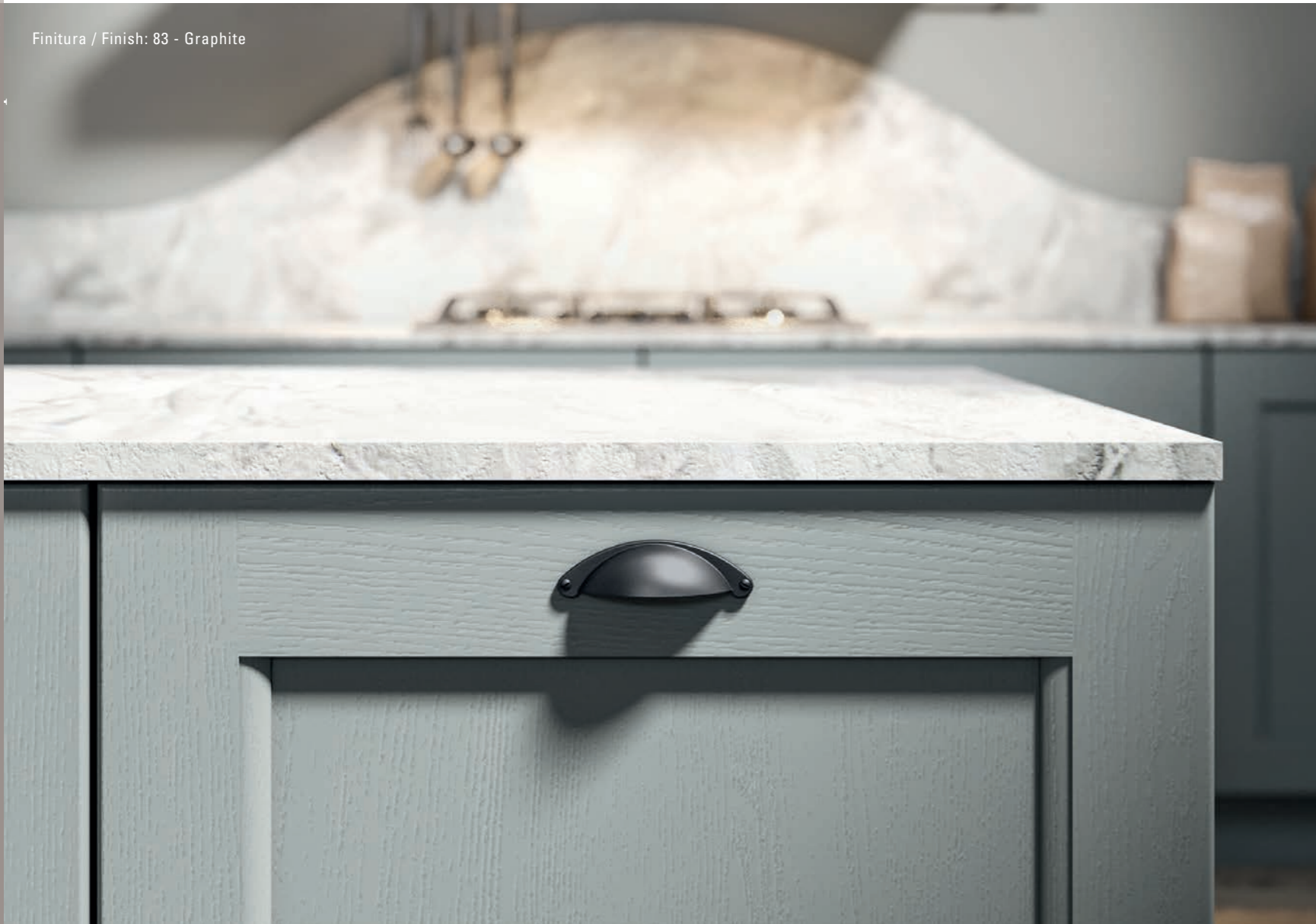

Finiture / Finishes

Crediamo fortemente nella Ricerca&Sviluppo, per questo proponiamo una nuova gamma di finiture che donano carattere ed espressione ad ogni ambiente casa.

Le texture e i colori delle finiture rappresentate hanno valore identificativo in quanto soggetti alle tolleranze dei processi di stampa. I nomi delle finiture sono nomi di fantasia e hanno valore puramente commerciale.

We strongly believe in Research&Development, that's why we offer a new range of finishes that give character and expression to any home Interior.

The texture and colors of finishes are not binding because they depend on printing colors tolerances. Finishes names are fancy names and have a purely commercial value.



Finiture metallizzate / Metallic finishes

7 nuove finiture, dai toni caldi e naturali, come il bronzo e l'oro, a tinte più neutre come il grigio e il nero. Finiture dall'effetto metallico e omogeneo, vernice di alta qualità, super durevole. Un mix perfetto tra i colori di tendenza e le esigenze dell'architettura e del design contemporaneo. Tutti i colori ALU sono disponibili in abbinamento all'intera collezione di prodotti MARELLA DESIGN: Unione di forma e colore per tutti i tipi di ispirazione.

The entire collection is available in 7 new finishes, from warm and natural nuances of Bronze and Gold to the more neutral ones of Black and dark grey. Finishes with a metallic look and homogenous effect, made with a high quality and durable coating. A perfect mix between trend colors and modern demand in the contemporary architectural and design era. All finishes are available to match the entire MARELLA DESIGN collection. The bond of Shapes and Colors for any inspiration.

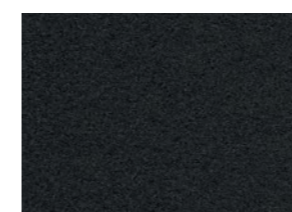

V1
Black Shimmer

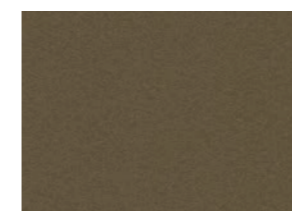

V3
Bronze

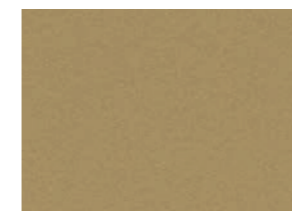

V5
Gold Shimmer



V7
Bollicine

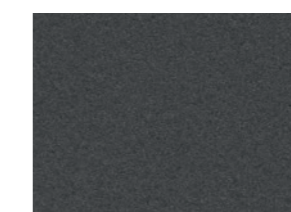

V2
Ardesia Shimmer



V4
Dark Bronze

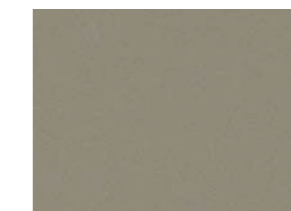

V6
Savannah



Finiture Silk effect / Silk effect finishes

Le finiture Silk effect sono una novità assoluta; super-opaco, con colori di tendenza, dall'effetto setoso e molto piacevole al tatto con caratteristiche tecniche molto performanti. L'offerta include 9 colori di tendenza, versatili ed ideali sia per l'applicazione tono su tono che a contrasto. Colori neutri, naturali, morbidi e caldi come il Tortora, Sand, Cacao, Cool Grey e Verde. Ci sono poi colori più audaci e vivaci come il Blu e il Bordeaux.

The Silk effect finishes are SUPER-MATT high performing brand new concepts that please the touch. The offer includes nine colors, versatile and ideal both for tone-on-tone as well as matching solutions. Neutral, natural, soft and warm colors such as Tortora, Sand, Cacao, Cool Grey and Green. Bold and aggressive colors such as Blue and Bordeaux.



T1
Tortora



T2
Sand

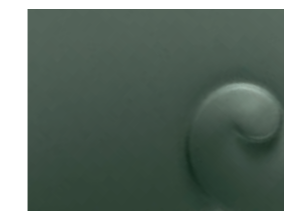

T3
Verde Malachite Silk Effect



T4
Blue Ocean Silk Effect



T5
Nero Silk Effect



T6
Bianco Silk Effect

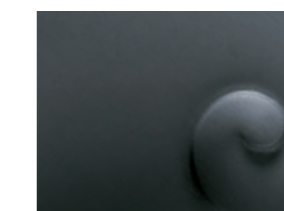

T7
Cool Grey Silk Effect

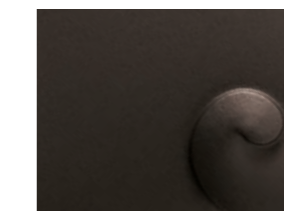



T8
Cacao Silk Effect





TF
Bordeaux Silk Effect

PLUS TECNICI / TECHNICAL PLUS

 **RESISTENTE AI GRAFFI E ALL'ABRASIONE ***
Resistant to scratches and abrasions *

 **ADATTO AD AMBIENTI UMIDI**
Suitable for humid environments

 **EXTRA MATT E ANTI RIFLESSO**
Extra matt and anti-glare

 **RESISTENTE AI LIQUIDI FREDDI**
Resistant to cold liquids

 **RESISTENTE AL SUDORE SINTETICO**
Resistant to synthetic sweat

 **EFFETTO SETA**
Silk effect

 **STABILITÀ ALLA LUCE**
Light stability

 **PULIZIA PRODOTTO**
Easy to clean

 **ANTI IMPRONTA**
Anti fingerprint

* Nel rispetto delle norme specificate nel certificato di Garanzia dell'azienda. / In compliance with the rules specified in the company's warranty certificate.



Finiture Trend / Trend finish

Le finiture Trend sono caratterizzate da colori grigi moderni, tonalità brown calde e avvolgenti e nuance dorate, eleganti e raffinate. Nuove proposte per dare spazio alla creatività di ognuno di noi e che si sposano perfettamente con i trend degli ambienti casa.

The trend finishes are characterized by modern colours like grey, warm and enveloping brown tones as well as elegant and refined golden nuances. New proposals to give space to the creativity of each of us and which blend perfectly with the trends of home environments.



DF
Bright bronze



DG
London grey



DH
Golden shadow



DT
Gold treasure



DS
Ottone / Brass

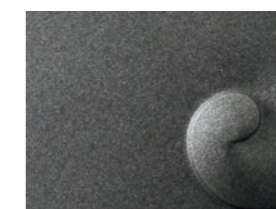

HA
Ardesia

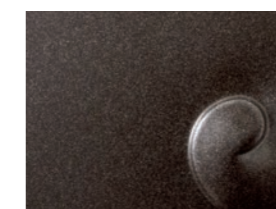

HB
Brown



HC
Champagne

Elenco finiture / Finishes list

CODICE FINITURA CODICE FINITURA	NOME NAME
03	Ottone Antico/Antique brass
05	Brunito/Burnished
06	Patinè France
07	Oro di Valenza
09	Florence
11	Poli Verni/ Polished brass
12	Ottone satinato/ Satin brass
15	Bagno Oro/ Gold plated
19	Similferro/similiron
20	Rustico
22	Old America
23	Rame Lucido/Bright copper
25	Argento Vecchio/ Old silver
28	Patiné Paris
29	Ramato Antico/ Antique copper
31	Nickel Opaco/ Mat nickel
32	Nickel lucido / Bright nickel
34	Nickel Satinato / Satin nickel Inox Aspect
36	Cromo lucido / Bright chrome
41	Golden White
45	Cromo opaco / Mat chrome
46	Oro Opaco / Mat gold
47	Argento Orientale / Oriental silver
48	Canna di Fucile
52	Silver White
54	Patiné BM
75	Bronze medaille
78	Bagno Argento/ Silver plated
83	Graphite
84	Cromo Satinato/ Satin chrome
85	Effetto Titanio/ Titanium effect
90	Terra di Siena
91	Pewter
92	Decapé
93	Velvet gold
94	Iron Effect
95	Iron Effect Mat
96	Cromo opaco verniciato/ Mat chrome painted
97	Nickel opaco verniciato / Mat nickel painted
98	Tobacco

CODICE FINITURA CODICE FINITURA	NOME NAME
DC	Rame satinato/ Brushed copper
DF	Bright bronze
DG	London grey
DH	Golden shadow
DI	Effetto cemento
DL	Rock
DM	Watery stone
DN	Rust looking
DO	Watery rust
DP	Ocra vintage
DQ	Blue washed
DR	Ivory gold
DS	Ottone / Brass
DT	Gold treasure
DU	Refined gold 24 Kt
DV	Refined silver
F4	Bianco lucido / Bright white - RAL 9010
F5	Bianco opaco / Mat white - RAL 9010
N1	Nero lucido/ Bright black - RAL 9005
N2	Nero opaco/ Mat black - RAL 9005
T1	Tortora silk effect
T2	Sand silk effect
T3	Verde Malachite silk effect
T4	Blue Ocean silk effect
T5	Nero silk effect
T6	Bianco silk effect
T7	Cool grey silk effect
T8	Cacao silk effect
TF	Bordeaux silk effect
HA	Ardesia
HB	Brown
HC	Champagne
V1	Black Shimmer
V2	Ardesia Shimmer
V3	Bronze
V4	Dark bronze
V5	Gold Shimmer
V6	Savannah
V7	Bollicine

Il nostro obiettivo è aumentare la Qualità Aziendale puntando sulla crescita del nostro personale e sul miglioramento dei processi produttivi, nel pieno rispetto dell'ambiente che ci circonda.

Our goal is to increase Company Quality by focusing on the growth of our staff and on the improvement of production processes, with full respect for environment around us.



100% Made In Italy
Certificate



UNI EN ISO 9001:2015
Certified Quality
System



UNI EN ISO 14001:2015
Environmental System

Tutti gli articoli in questo catalogo sono ideati e realizzati interamente da **ROBERTO MARELLA S.p.A.** in collaborazione con designers di fama del settore.

All items in this catalogue are designed and manufactured by **ROBERTO MARELLA S.p.A.** in collaboration with renowned designers of the sector.
Copyright©2023 ROBERTO MARELLA S.p.A.

È vietata ogni riproduzione con qualunque mezzo, senza preventiva autorizzazione scritta da parte di ROBERTO MARELLA S.p.A. Ogni trasgressione sarà punita a norma di legge.

Bosetti Marella e Marella Design sono marchi commerciali registrati di proprietà ROBERTO MARELLA S.p.A.

No parts of this work may be reproduced or copied in any way or by any means, without written permission from Roberto Marella S.p.A. Violators will be prosecuted.

Bosetti Marella and Marella Design are registered trademarks of Roberto Marella S.p.A.

Tutte le misure sono espresse in mm. / All sizes are in mm.

AVVERTENZE

Roberto Marella S.p.A. si riserva la facoltà di modificare le caratteristiche tecniche dei prodotti a catalogo, in qualunque momento.

Per ragioni tecniche, le tonalità dei colori nelle fotografie, possono non rappresentare fedelmente la realtà. Si raccomanda la pulizia con panno umido, evitando l'impiego di detersivi.

Si prega di consultare il documento di Garanzia del prodotto per qualsiasi ulteriore informazione.

ATTENTION

Roberto Marella S.p.A. reserves the right to change technical details of products illustrated in this catalogue, whenever necessary.

Due to technical reasons, pictures colors could be different from the original colors.

We recommend to clean our products with a dry cloth, avoiding the use of detergents or alcohol.

Please refer to the product warranty document for any further information.